

The background of the entire page is a blue-tinted image of a space station or satellite in orbit. Overlaid on this image are several white and yellow circuit-like lines that start from the left edge and branch out towards the center and right, ending in small circles. These lines are positioned to frame the main title text.

MIL-STD-1553 B Databus harnesses

DATABUS

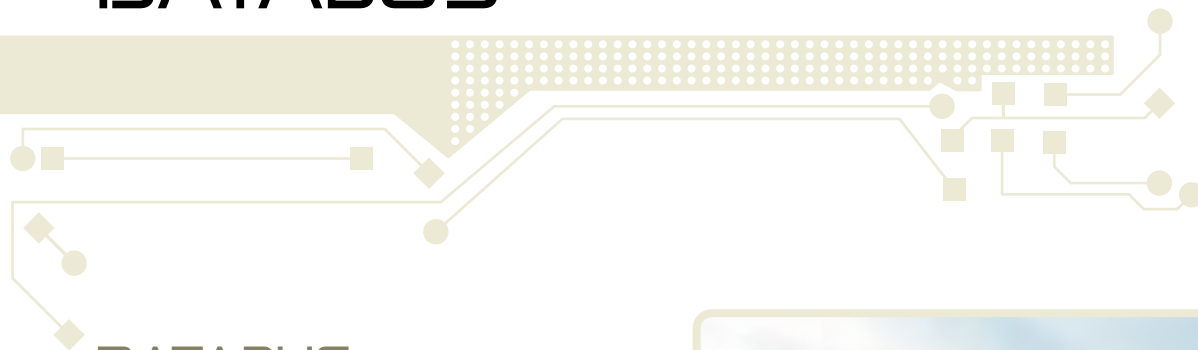

DATABUS

MIL-STD-1553 B DATABUS

HARNESSESE-3

Identification codesE-4

Databus cableE-6

Cable constructionE-7

1 way in-line couplerE-8

1 way in-line coupler with terminator.....E-10

2 way in-line couplerE-12

2 way in-line coupler with terminator.....E-14

3 way in-line couplerE-16

3 way in-line coupler with terminator.....E-18

4 way in-line couplerE-20

4 way in-line coupler with terminator.....E-22

1 way in-line direct couplerE-24

1 way in-line ESD couplerE-26

2 way in-line ESD couplerE-28

3 way in-line ESD couplerE-30

Detailed AMB technical informationsE-32

ACB1 DATABUS CONNECTORS

& CONTACTSE-33

Pin and socket contactE-34

ACB1 databus connectorE-36

– *bulkhead jack straight bayonet*E-36

– *bulkhead jack elbow bayonet*E-38

– *plug straight bayonet*E-40

– *plug jack elbow bayonet*E-42

– *bulkhead jack pigtail bayonet*E-44

Detailed ACB1 technical informationsE-46

SPLICES & TERMINATORSE-47

In-line databus terminatorE-48

In-line ESD databus terminatorE-49

Dismountable bus terminator
or stub impedanceE-50

D-Sub dismountable bus terminator
or stub impedanceE-51

ACB1 dismountable databus terminator
or stub impedanceE-52

ACB1 databus connectorE-54

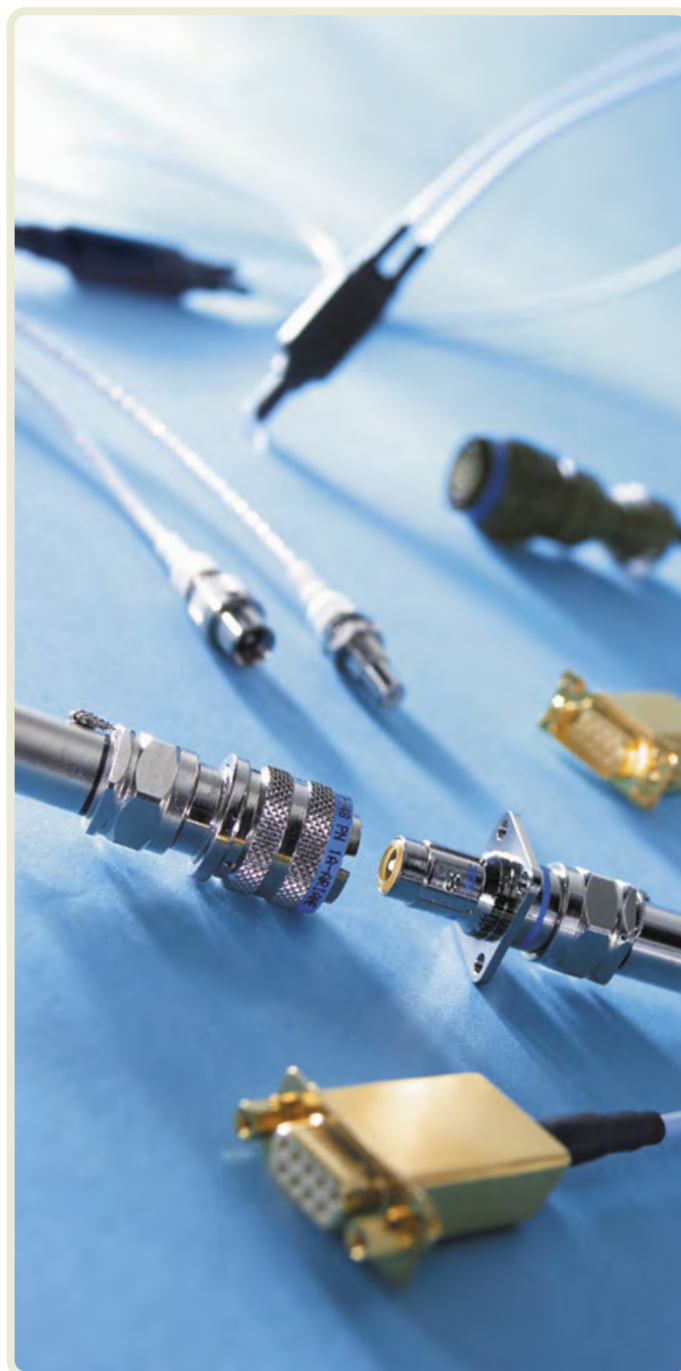

MIL-STD-1553 B databus harnesses

AXON' DATABUS HARNESSSES AND COMPONENTS

Axon' Cable designs and manufactures all components used in data transmission systems in compliance with the **MIL-STD-1553 standard**. This is the protocol of dialogue for strategic **on-board** systems for aeronautics, space and military applications. These reliable transmission networks offer high security of data, signal integrity, weight and space saving, as well as rapid diagnostics of all equipment connected to the bus. Axon' has developed inline couplers, cables, terminators, splices and connectors made with space-grade materials and according to ESA manufacturing procedures (PID & French Space Agency CNES approvals).

The datasheets included in this brochure help you choose the very databus harnesses you need. The identification code (page "In-line coupler identification code", page E-4) gives you an overview of all our databus cables references including aeronautics (A) and space (S) versions.

Space databus cables

Databus cables for space applications (References: 40, 41, 43, 44 and 45) are 2219 AWG, 2419 AWG and 2619 AWG screened twisted-pair cables insulated with PTFE or PFA. They are designed to resist corrosion. The most common used are AWG2419 cables. Depending on the level of electromagnetic efficiency, single or double braid constructions are available.

Space couplers

Please consult our datasheets to choose the best solution for your routing: number of stubs, PCB routing, integrated terminators should be considered.

Databus connectors

Axon' has developed a triaxial connector called ACB1 suitable for any type of twisted shielded AWG 24 pair cables. This is the only connector approved to ESCC 3401/079 by ESA.

Terminators and splices

Axon' offers accessories including 77 or 3 Ω removable terminators and splices. Terminators with ESD protection are available.



MANUFACTURE OF HARNESSSES IN ISO 8 CLEAN ROOM



MIL-STD-1553 HARNESS

In-line coupler identification code

AMB/ S - C_x - XX - XX ^ XX - XX

AXON' MICROBUS

AERONAUTICS VERSION **A**
EUROFIGHTER VERSION **E**
SPACE VERSION **S**

- C1:** 1 WAY IN-LINE COUPLER with bus lines on opposite sides of the coupler
C11: 1 WAY IN-LINE COUPLER with bus lines on same side of the coupler
C2: 2 WAY IN-LINE COUPLER with bus lines on opposite sides of the coupler
C21: 2 WAY IN-LINE COUPLER with bus lines on same side of the coupler
C3: 3 WAY IN-LINE COUPLER with bus lines on opposite sides of the coupler
C31: 3 WAY IN-LINE COUPLER with bus lines on same side of the coupler
C4: 4 WAY IN-LINE COUPLER with bus lines on opposite sides of the coupler
C41: 4 WAY IN-LINE COUPLER with bus lines on same side of the coupler

CABLE REFERENCES

(See cable construction pages E-6 & E-7)

- 10:** TWINAX BUS 10 AWG 24 SB [single braid] according to MIL-C17/176-00002 **A**
20 = TWINAX BUS 20 AWG 24 SB [single braid] accord. to pr EN 3375-003 **A**
21 = TWINAX BUS 21 AWG 24 DB [double braid] accord. to pr EN 3375-004 **A**
22 = TWINAX BUS 22 AWG 24 HI [high immunity] accord. to pr EN 3375-005 **A**
31 = TWINAX BUS 31 AWG 24 DB [double braid] according to PAN6421 **E**
40 = TWINAX BUS 40 AWG 24 SB [single braid] according to SSQ 21655 Rev. E **S**
41 = TWINAX BUS 41 AWG 24 DB [double braid] **S**
43 = TWINAX BUS 43 AWG 26 SB [single braid] **S**
44 = TWINAX BUS 44 AWG 26 DB [double braid] **S**
45 = TWINAX BUS 45 AWG 22 SB [single braid] according to SSQ 21655 Rev. E **S**
60 = TWINAX BUS 60 AWG 24 SB [single braid] **E A**
61 = TWINAX BUS 61 AWG 24 DB [double braid] **E A**
70 = TWINAX BUS 70 AWG 26 SB [single braid] **A**
71 = TWINAX BUS 71 AWG 26 DB [double braid] according to ECS 0700 **A**
72 = TWINAX BUS 72 AWG 26 HI [high immunity] **A**
80 = TWINAX BUS 80 AWG 24 SB [single braid] acc. to ESCC 3902 002 20 [black] **S**

CABLE LENGTH

(in meters)

COLOUR OF THE BUS LINE

H = blue
L = white

COLOUR OF THE STUB LINE

H = blue
L = white

S = blue with black stripes if the bus is blue
or white with blue stripes if the bus is white

B = only for & mandatory for TWINAX BUS 80 AWG 24 SB

INTEGRATED TERMINATOR

TL = Terminator on left side of coupler

TR = Terminator on right side of coupler

TT = Terminator on both sides

Blank = No terminator

ATTENTION: please see the technical data sheets to verify the compatibility between the coupler version, cable type and cable colour. Verify also the existence of the coupler and the colour of the cable.

Terminator identification code

AMB/ S - I - XX - XX ^ X

AXON' MICROBUS

AERONAUTICS VERSION **A**
EUROFIGHTER VERSION **E**
SPACE VERSION **S**

IN-LINE BUS TERMINATOR

CABLE REFERENCES

(See cable specifications pages E-6 & E-7)

- 10 = TWINAX BUS 10 AWG 24 SB [single braid] according to MIL-C17/176-00002 **A**
- 20 = TWINAX BUS 20 AWG 24 SB [single braid] accord. to pr EN 3375-003 **A**
- 21 = TWINAX BUS 21 AWG 24 DB [double braid] accord. to pr EN 3375-004 **A**
- 22 = TWINAX BUS 22 AWG 24 HI [high immunity] accord. to pr EN 3375-005 **A**
- 31 = TWINAX BUS 31 AWG 24 DB [double braid] according to PAN6421 **E**
- 40 = TWINAX BUS 40 AWG 24 SB [single braid] according to SSQ 21655 Rev. E **S**
 - 41 = TWINAX BUS 41 AWG 24 DB [double braid] **S**
 - 43 = TWINAX BUS 43 AWG 26 SB [single braid] **S**
 - 44 = TWINAX BUS 44 AWG 26 DB [double braid] **S**
- 45 = TWINAX BUS 45 AWG 22 SB [single braid] according to SSQ 21655 Rev. E **S**
 - 60 = TWINAX BUS 60 AWG 24 SB [single braid] **E A**
 - 61 = TWINAX BUS 61 AWG 24 DB [double braid] **E A**
 - 70 = TWINAX BUS 70 AWG 26 SB [single braid] **A**
- 71 = TWINAX BUS 71 AWG 26 DB [double braid] according to ECS 0700 **A**
- 72 = TWINAX BUS 72 AWG 26 HI [high immunity] **A**
- 80 = TWINAX BUS 80 AWG 24 SB [single braid] acc. to ESCC 3902 002 20 [black] **S**

CABLE LENGTH

(in meters)

COLOUR OF CABLE

H = blue
L = white
B = only for & mandatory for TWINAX BUS 80 AWG 24 SB

Databus cable

SPECIFICATIONS

MIL-STD-1553B
MIL-C-17/176-00002
pr EN 3375
PANAVIA 6421
ECS 0700
SSQ 21655

Operating temperature

-55°C to +200°C, -65°C to +200°C, -65°C à +150°C, +200°C or -200°C to +180°C
depending on applicable standards

Characteristic impedance

77 \pm 7 Ω at 1 MHz

Linear capacitance between wires see table on next page.

TYPE A (*)

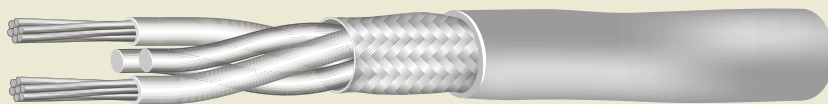

TYPE B (*)

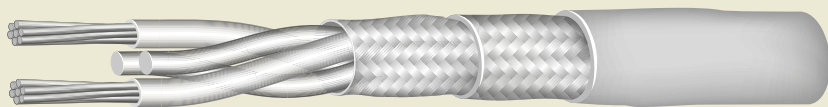

TYPE C (*)

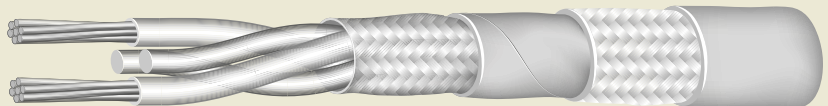

TYPE D (*)

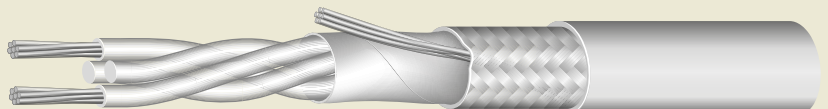

(*) See cable type in the chart on the next page

Special cable versions

- Supplementary jacket or protection on the jacket.
- Insertion of the bus cables inside a complex round construction.
- In some cases possibility to differentiate bus and stub cable with a striped colour tape under the transparent jacket or the extrusion of a colour jacket.

Transfer impedance standard values (m Ω /m max)

TYPE OF CABLE	CONSTRUCTION	FREQUENCY			
		0 Hz	1 MHz	10 MHz	30 MHz
TWINAX BUS 10	A	30	40	100	200
TWINAX BUS 20	A	45	45	45	100
TWINAX BUS 21	B	15	5	5	10
TWINAX BUS 22	C	15	0.025	0.025	0.1
TWINAX BUS 31 or 61	B	20	10	10	10
TWINAX BUS 40	A	30	40	100	200
TWINAX BUS 41	B	15	5	5	10
TWINAX BUS 43 or 70	A	70	75	90	140
TWINAX BUS 44 or 71	B	30	30	15	15
TWINAX BUS 80	D	30	40	100	200

NOTE: The transfer impedance values of the TWINAX BUS 20, 21, 22 and 31 cables are specified in the corresponding standards. The values of the other cable types are guaranteed by AXON'.

Cable construction

PRODUCT	VERSIONS	SPECIFICATION	CABLE		PRIMARY WIRE		SHIELD NOM. Ø (mm)	BRAID & TAPE MATERIAL	OUTER JACKET	INSULATED CABLE		CAPACITY pF/m
			TYPE	AWG	CONDUCTOR MATERIALS AND CONSTRUCTION	DIELECTRIC AND FILLER MATERIALS				OUTER Ø (mm)	WEIGHT (g/m)	
TWINAX BUS 10 P502810	A	MIL-STD-1553B MIL-C-17/176-00002	A	24	SPC alloy 19 x 0.127 mm	Extruded PTFE	2.60	Single braid: SPC alloy	PFA	3.15 to 3.40	26.80 max.	< 78.75
TWINAX BUS 20 P502805	A	MIL-STD-1553B NF-L-52161-1 pr EN 3375-003	A	24	SPC alloy 19 x 0.120 mm	Extruded PTFE	2.58	Single braid: SPC	FEP	3.10 to 3.30	24.00 max.	< 78.75
TWINAX BUS 21 P512806	A	MIL-STD-1553B NF-L-52161-2 pr EN 3375-004	B	24	SPC alloy 19 x 0.120 mm	Extruded PTFE	3.00	Double braid: SPC	FEP	3.60 to 3.80	37.00 max.	< 78.75
TWINAX BUS 22 P512807	A	MIL-STD-1553B NF-L-52161-3 pr EN 3375-005	C	24	SPC alloy 19 x 0.120 mm	Extruded PTFE	3.10	Double braid: SPC - High magnetic permeability tape	FEP	3.70 to 3.90	43.30 max.	< 78.75
TWINAX BUS 31 PANAVIA BUS P507991	E	MIL-STD-1553B PAN 6421	B	24	SPC alloy 19 x 0.118 mm	Polyimide tape and PTFE filler	3.24	Double braid: SPC	FEP	3.50 to 3.80	29.00 max.	< 98.40
TWINAX BUS 40 BUS BOEING/NASA NDBC-TFE-24S2SJ-75 P512296	S	MIL-STD-1553B SSQ 21655 Rev. E	A	24	SPC alloy 19 x 0.127 mm Silver plating 2µm	Extruded PTFE	2.58	Single braid: SPC alloy Silver plating 2µm	FEP	3.175 to 3.37	22.00 nom.	< 80.00
TWINAX BUS 41 P546162	S	MIL-STD-1553B	B	24	SPC alloy 19 x 0.120 mm Silver plating 2µm	Extruded PTFE	3.00	Double braid: SPC Silver plating 2µm	FEP	3.60 to 3.80	37.00 max.	< 78.75
TWINAX BUS 43 P541610	S	MIL-STD-1553B	A	26*	SPC alloy 19 x 0.102 mm Silver plating 2µm	Extruded PTFE	2.05	Single braid: SPC Silver plating 2µm	FEP	2.40 to 2.60	14.60 nom.	< 78.75
TWINAX BUS 44 P530781	S	MIL-STD-1553B	B	26*	SPC alloy 19 x 0.102 mm Silver plating 2µm	Extruded PTFE	2.40	Double braid: SPC Silver plating 2µm	FEP	2.80 to 3.00	20.00 nom.	< 80.00
TWINAX BUS 45 BUS BOEING/NASA NDBC-TFE-22S2SJ-75 P812302	S	MIL-STD-1553B SSQ 21655 Rev. E	A	22*	SPC alloy 19 x 0.16 mm Silver plating 2µm	CELLOFLON® expanded PTFE	3.09	Single braid: SPC alloy Silver plating 2µm	FEP	3.76 to 4.06	27.70 nom.	< 80.00
TWINAX BUS 60 P819845	A	MIL-STD-1553B	A	24	SPC alloy 19 x 0.127 mm	CELLOFLON® expanded PTFE	2.41	Single braid: SPC alloy	FEP	2.90 to 3.10	18.00 nom.	< 70.00
TWINAX BUS 61 P815721	A	MIL-STD-1553B	B	24	SPC alloy 19 x 0.127 mm	CELLOFLON® expanded PTFE	2.76	Double braid: SPC alloy	FEP	3.10 to 3.30	24.00 nom.	< 70.00
TWINAX BUS 70 P504621	A	MIL-STD-1553B	A	26*	SPC 19 x 0.102 mm	Extruded PTFE	2.05	Single braid: SPC	FEP	2.40 to 2.60	14.60 nom.	< 78.75
TWINAX BUS 71 P517417	A	MIL-STD-1553B ECS 0700	B	26*	SPC alloy 19 x 0.102 mm	Extruded PTFE	2.40	Double braid: SPC	FEP	2.80 to 3.00	21.00 max.	< 80.00
TWINAX BUS 72 P511981	A	MIL-STD-1553B	C	26	SPC 19 x 0.102 mm	Extruded PTFE	2.45	Double braid: SPC-High magnetic permeability tape	FEP	2.90 to 3.10	25.00 nom.	< 80.00
TWINAX BUS 80 ESCC 3902.002.20 P538524	S	ESCC 3902.002.20	D	24	SPC alloy 19 x 0.126 mm Silver plating 2µm	Dielectric: Wrapped PTFE Filler: Extruded PTFE	2.75	Single braid: SPC alloy Silver plating 2,5µm	PFA	3.90 max.	24.00 max.	<68.00

OTHER CABLES ON REQUEST.

SPC: Silver Plated Copper - * In case of AWG 26 or AWG 22 cable, please ask AXON' for compatibility with crimp connectors.

A = AERONAUTICS - E = EUROFIGHTER - S = SPACE

To see how are constructed each cable type, please see page E-6.

1 way in-line coupler

SPECIFICATIONS

Microcoupler
MIL-STD-1553B (STANAG 3838)
SSQ 21676 (NASA-BOEING)
PID (CNES), SPE-J-403-A-0070

Testing
AS-SAE-4115

Resistor
MIL-R-39007

Solder
ECSS-Q-ST-70-08,
MIL-STD-2000, NHB 5300.4.

Derating
ECSS-Q-ST-30-11

Potting material
ECSS-Q-ST-70-02, ASTM E595,
and ECSS-Q-ST-70-29
or NHB 8060.1.

Connector assemblies
ECSS-Q-ST-70-26
or NHB 5300.4.

Transformer
JN1081 approved
DDP-J-403-A-022
ESA approved
(COF-BCS-PAD01)

All processes, materials
and components are
approved by CNES
(see CNES-PID-02-AXON*)
and BOEING/NASA.

ESA: European Space Agency
CNES: French Space Agency
PID: Part Identification Document

AMB / S - C1 - XX

Version with bus lines on opposite sides of the coupler.

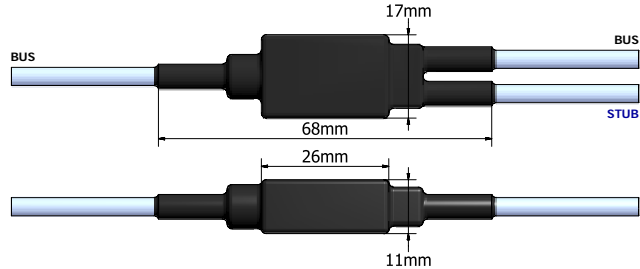

AMB / S - C11 - XX

Version with bus lines on same side of the coupler.

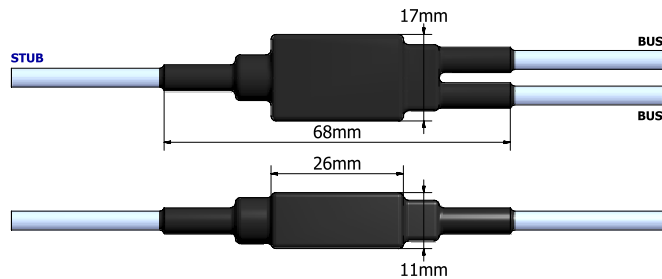

Electrical scheme

$$N = 1.41 \pm 3\%$$

R = fault protection resistance

$$R = 0.75 Z_0 = 57.6 \Omega \pm 1\%$$

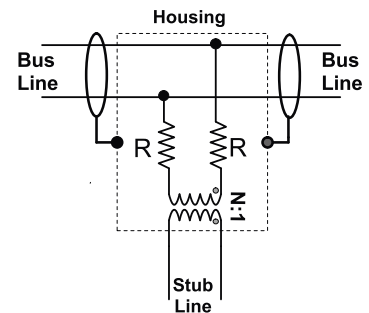

Identification code

AMB /

S

CX

XX

AXON[®]
MICROBUS
(see complete
reference of
the coupler
on Bus
Standard
sheet, page
E-4).

**S: SPACE
VERSION**

1: 1 WAY IN-LINE COUPLER

Version with bus lines on
opposite sides of the coupler.

11: 1 WAY IN-LINE COUPLER

Version with bus lines on
same side of the coupler.

CABLE REFERENCES

40: TWINAX BUS AWG 24 SB (single braid) acc. to SSQ 21655 (NASA qualified).

41: TWINAX BUS AWG 24 DB (double braid).

43: TWINAX BUS AWG 26 SB (single braid).

44: TWINAX BUS AWG 26 DB (double braid).

45: TWINAX BUS AWG 22 SB (single braid) acc. to SSQ 21655 (NASA qualified).

80: TWINAX BUS AWG 24 SB (single braid) according to ESCC 3902.002.20.

NOTE: CABLE LENGTH AND CABLE COLOUR TO BE DEFINED WHEN ORDERING (possibility to differentiate bus and stub cable with a striped colour tape under the transparent jacket or the extrusion of a colour jacket).
See page E-10 for couplers with integrated terminator(s).

Electrical characteristics

PARAMETERS	REQUIRED	ACTUAL
Nominal line impedance*	70 to 84 Ω	77 Ω
Turn ratio	1.41 \pm 3%	1.41 \pm 3%
CMR	< -45 dB at 1 MHz	< -50 dB at 1 MHz
Input impedance	> 3000 Ω in the frequency range (75 kHz to 1 MHz) and in the indicated temp. range (-65°C to 150°C)	> 3000 Ω
Fault protection insulation resistors in series on each bus winding connection	0.75 $Z_o \pm$ 2%	57.6 $\Omega \pm$ 1%
Insulation resistance between:		
- bus / stub	100 M Ω	> 1 000 M Ω at 250 V _{DC}
- inner wires / shield	100 M Ω	> 1 000 M Ω at 500 V _{DC}
Transfer impedance	-	plot available
Shield continuity	-	10 m Ω maximum
Shield coverage	Cable 90% Connection 75%	Cable 90% minimum Connection 100%
Dielectric withstanding strength:		
- between shield and inner wires	500 V _{RMS}	500 V _{RMS}
- between outer insulation and shield	500 V _{RMS}	500 V _{RMS}

* Impedance: seen from the stub when the bus line is loaded with Z_o at both sides of the coupler.

Environmental characteristics

PARAMETERS	REQUIRED	ACTUAL
Operating temperature	-	-65°C to +150°C
Out-gassing	SP-R-0022 - TML < 1% ASTM-E-595 - CVCM < 0.1% ECSS-Q-ST-70-02	TML = 0.0005% RML = 0000027% CVCM = 0%
Off-gassing	NHB 8060.1 Test 7 ECSS-Q-ST-70-29	T = 0.00024 for 65 m ³ volume per coupler* MLW (#) = 2112 for 65 m ³ volume*
MTBF according to MIL HDBK-217	-	5.25 x 10 ⁷ hrs at 25°C and Space Flight environment

Out and Off-gassing results, flammability available for all materials used.

* Typical values obtained by AMB/S-C1 coupler during qualification phase.

Mechanical characteristics

PARAMETERS	REQUIRED	ACTUAL
Weight	-	\leq 10 g
Life test	-	1000 hrs at 120°C
Shocks	-	15 g's in all directions
Acceleration	-	20 g's in all directions
Random vibrations	MIL-STD-810, Method 514.5	Functional at 120°C = 16.35 g _{RMS} Endurance at 20°C = 33.23 g _{RMS}

Other mechanical and environmental tests available on request.

Transformer characteristics

PARAMETERS	REQUIRED VALUES (MIL-STD-1553B or SAE AS-4115)	NOMINAL VALUE OR AXON' REQUIRED VALUE	
		NOMINAL VALUE	REQUIRED BY AXON' / QUALITY PLAN
The Curie point	-	-	Over 195°C
Turn ratio	$\sqrt{2} \pm$ 3%	$\sqrt{2} \pm$ 3%	$\sqrt{2} \pm$ 3%
Secondary DC resistance	$R_s < 5 \Omega$	$R_s = 2 \Omega$	$R_s < 2.5 \Omega$
Insulation resistance (winding to winding)	$R_i > 100 M\Omega$	-	$R_i > 1 000 M\Omega$ with a 250 V _{DC} test voltage
Transformer open circuit impedance	$ Z > 3 k\Omega$ on full temperature operating range	$ Z > 10 k\Omega$ at 25°C $ Z > 4.8 k\Omega$ at -65°C	$ Z > 4 k\Omega$ at -85°C $ Z > 9.4 k\Omega$ at 25°C***
Primary parallel inductance	-	22 mH	> 20 mH
Primary parallel capacitance	-	10 pF	< 11.4 pF
Inter-winding capacitance	-	45 pF	-
Primary leakage inductance	-	-	< 6.0 μ H
Droop*	< 20%	4.5%**	< 20%**
Overshoot and ringing*	\pm 1 V	0.30 V**	< \pm 1 V**

* Tested with a 250 kHz square waveform of 27 V_{PP} with 100 ns rise and fall times through a 360 \pm 5% Ω resistor.

** Average values taken during the JN1081N qualification.

*** 9.4 k Ω at 25°C guarantees 3 k Ω from -65°C to +150°C

1 way in-line coupler with terminator

SPECIFICATIONS

Microcoupler
MIL-STD-1553B (STANAG 3838)
SSQ 21676 (NASA-BOEING)
PID (CNES), SPE-J-403-A-0070

Testing
AS-SAE-4115

Resistor
MIL-R-39007

Solder
ECSS-Q-ST-70-08,
MIL-STD-2000, NHB 5300.4.

Derating
ECSS-Q-ST-30-11

Potting material
ECSS-Q-ST-70-02, ASTM E595,
and ECSS-Q-ST-70-29
or NHB 8060.1.

Connector assemblies
ECSS-Q-ST-70-26
or NHB 5300.4.

Transformer
JN1081 approved
DDP-J-403-A-022
ESA approved
(COF-BCS-PAD01)

All processes, materials
and components are
approved by CNES
(see CNES-PID-02-AXON')
and BOEING/NASA.

ESA: European Space Agency
CNES: French Space Agency
PID: Part Identification Document

AMB / S - C1 - XX - T RIGHT 'TR'

Version with bus and stub lines on opposite sides of the coupler.

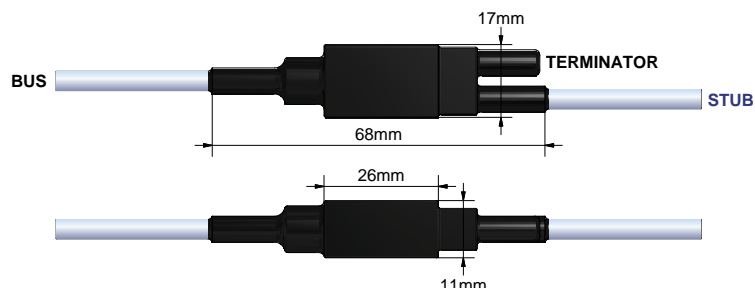

AMB / S - C1 - XX - T LEFT 'TL'

Version with bus and stub lines on same side of the coupler.

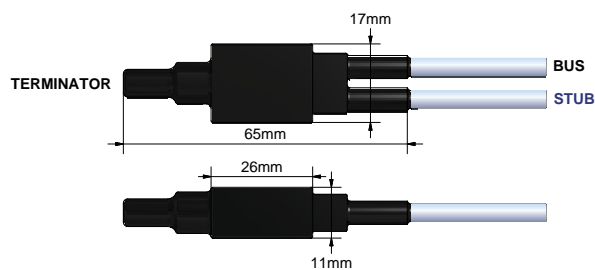

Electrical scheme

$N = 1.41 \pm 3\%$

$R = \text{fault protection resistance}$

$R = 0.75 Z_0 = 57.6 \Omega \pm 1\%$

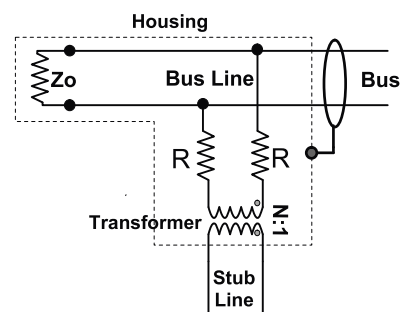

Identification code

AMB /

S

CX

XX

XX

AXON' MICROBUS
(see complete reference of the coupler on Bus Standard sheet, page E-4).

S: SPACE VERSION

1: 1 WAY IN-LINE COUPLER
Version with bus lines on opposite sides of the coupler.

CABLE REFERENCES

40: TWINAX BUS AWG 24 SB (single braid) acc. to SSQ 21655 (NASA qualified).

41: TWINAX BUS AWG 24 DB (double braid).

43: TWINAX BUS AWG 26 SB (single braid).

44: TWINAX BUS AWG 26 DB (double braid).

45: TWINAX BUS AWG 22 SB (single braid) acc. to SSQ 21655 (NASA qualified).

80: TWINAX BUS AWG 24 SB (single braid) according to ESCC 3902.002.20.

TR: T RIGHT

Bus and stub on opposite sides.

TL: T LEFT

Bus and stub on same side of the coupler.

NOTE: CABLE LENGTH AND CABLE COLOUR TO BE DEFINED WHEN ORDERING (possibility to differentiate bus and stub cable with a striped colour tape under the transparent jacket or the extrusion of a colour jacket).
See page E-8 for couplers without integrated terminator(s).

Electrical characteristics

PARAMETERS	REQUIRED	ACTUAL
Nominal line impedance*	70 to 84 Ω	77 Ω
Turn ratio	1.41 \pm 3%	1.41 \pm 3%
CMR	< -45 dB at 1 MHz	< -50 dB at 1 MHz
Terminator impedance	77 Ω \pm 2%	77 Ω \pm 1%
Fault protection insulation resistors in series on each bus winding connection	0.75 Z_0 \pm 2%	57.6 Ω \pm 1%
Insulation resistance between:		
- bus / stub	100 M Ω	> 1 000 M Ω at 250 V _{DC}
- inner wires / shield	100 M Ω	> 1 000 M Ω at 500 V _{DC}
Transfer impedance	-	plot available
Shield continuity	-	10 m Ω maximum
Shield coverage	Cable 90% Connection 75%	Cable 90% minimum Connection 100%
Dielectric withstanding strength:		
- between shield and inner wires	500 V _{RMS}	500 V _{RMS}
- between outer insulation and shield	500 V _{RMS}	500 V _{RMS}

* Impedance: seen from the stub when the bus line is loaded with Z_0 at both sides of the coupler.

Environmental characteristics

PARAMETERS	REQUIRED	ACTUAL
Operating temperature	-	-65°C to +150°C
Out-gassing	SP-R-0022 - TML < 1% ASTM-E-595 - CVCM < 0.1% ECSS-Q-ST-70-02	TML = 0.0005% RML = 0000027% CVCM = 0%
Off-gassing	NHB 8060.1 Test 7 ECSS-Q-ST-70-29	T = 0.00024 for 65 m ³ volume per coupler* MLW (#) = 2112 for 65 m ³ volume*
MTBF according to MIL HDBK-217	-	5.24 x 10 ⁷ hrs at 25°C and Space Flight environment

Out and Off-gassing results, flammability available for all materials used.

* Typical values obtained by AMB/S-C1 coupler during qualification phase.

Mechanical characteristics

PARAMETERS	REQUIRED	ACTUAL
Weight	-	≤ 12 g
Life test	-	1000 hrs at 120°C
Shocks	-	15 g's in all directions
Acceleration	-	20 g's in all directions
Random vibrations	MIL-STD-810, Method 514.5	Functional at 120°C = 16.35 g _{RMS} Endurance at 20°C = 33.23 g _{RMS}

Other mechanical and environmental tests available on request.

Transformer characteristics

PARAMETERS	REQUIRED VALUES (MIL-STD-1553B or SAE AS-4115)	NOMINAL VALUE OR AXON' REQUIRED VALUE	
		NOMINAL VALUE	REQUIRED BY AXON' / QUALITY PLAN
The Curie point	-	-	Over 195°C
Turn ratio	$\sqrt{2} \pm 3\%$	$\sqrt{2} \pm 3\%$	$\sqrt{2} \pm 3\%$
Secondary DC resistance	$R_s < 5 \Omega$	$R_s = 2 \Omega$	$R_s < 2.5 \Omega$
Insulation resistance (winding to winding)	$R_i > 100 M\Omega$	-	$R_i > 1 000 M\Omega$ with a 250 V _{DC} test voltage
Transformer open circuit impedance	$ Z > 3 k\Omega$ on full temperature operating range	$ Z > 10 k\Omega$ at 25°C $ Z > 4.8 k\Omega$ at -65°C	$ Z > 4 k\Omega$ at -85°C $ Z > 9.4 k\Omega$ at 25°C***
Primary parallel inductance	-	22 mH	> 20 mH
Primary parallel capacitance	-	10 pF	< 11.4 pF
Inter-winding capacitance	-	45 pF	-
Primary leakage inductance	-	-	< 6.0 μ H
Droop*	< 20%	4.5%**	< 20%**
Overshoot and ringing*	$\pm 1 V$	0.30 V**	< $\pm 1 V^{**}$

* Tested with a 250 kHz square waveform of 27 V_{PP} with 100 ns rise and fall times through a 360 \pm 5% Ω resistor.

** Average values taken during the JN1081N qualification.

*** 9.4 k Ω at 25°C guarantees 3 k Ω from -65°C to +150°C

2 way in-line coupler

SPECIFICATIONS

Microcoupler
MIL-STD-1553B (STANAG 3838)
SSQ 21676 (NASA-BOEING)
PID (CNES), SPE-J-403-A-0070

Testing
AS-SAE-4115

Resistor
MIL-R-39007

Solder
ECSS-Q-ST-70-08,
MIL-STD-2000, NHB 5300.4.

Derating
ECSS-Q-ST-30-11

Potting material
ECSS-Q-ST-70-02, ASTM E595,
and ECSS-Q-ST-70-29
or NHB 8060.1.

Connector assemblies
ECSS-Q-ST-70-26
or NHB 5300.4.

Transformer
JN1081 approved
DDP-J-403-A-022
ESA approved
(COF-BCS-PAD01)

All processes, materials
and components are
approved by CNES
(see CNES-PID-02-AXON')
and BOEING/NASA.

ESA: European Space Agency
CNES: French Space Agency
PID: Part Identification Document

AMB / S - C2 - XX

Version with bus lines on opposite sides of the coupler.

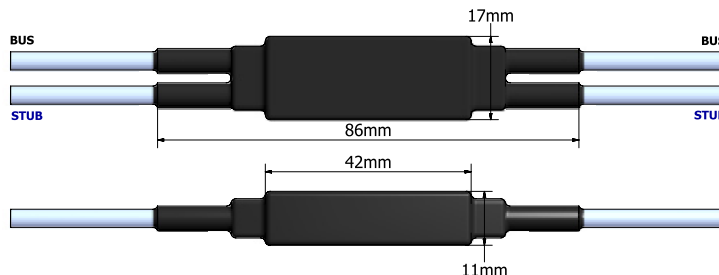

AMB / S - C21 - XX

Version with bus lines on same side of the coupler.

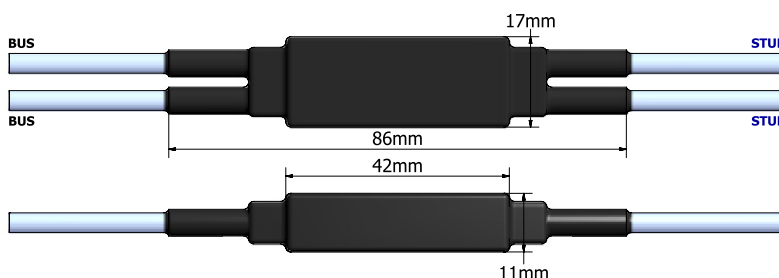

Electrical scheme

$N = 1.41 \pm 3\%$

$R = \text{fault protection resistance}$

$R = 0.75 Z_0 = 57.6 \Omega \pm 1\%$

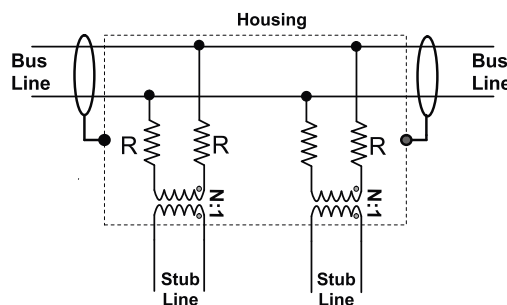

Identification code

AMB /

S

CX

XX

AXON' MICROBUS
(see complete reference of the coupler on Bus Standard sheet, page E-4).

S: SPACE VERSION

2: 2 WAY INLINE COUPLER

Version with bus lines on opposite sides of the coupler.

21: 2 WAY INLINE COUPLER

Version with bus lines on same side of the coupler.

CABLE REFERENCES

40: TWINAX BUS AWG 24 SB (single braid) acc. to SSQ 21655 (NASA qualified).

41: TWINAX BUS AWG 24 DB (double braid).

43: TWINAX BUS AWG 26 SB (single braid).

44: TWINAX BUS AWG 26 DB (double braid).

45: TWINAX BUS AWG 22 SB (single braid) acc. to SSQ 21655 (NASA qualified).

80: TWINAX BUS AWG 24 SB (single braid) according to ESCC 3902.002.20.

NOTE: CABLE LENGTH AND CABLE COLOUR TO BE DEFINED WHEN ORDERING (possibility to differentiate bus and stub cable with a striped colour tape under the transparent jacket or the extrusion of a colour jacket).
See page E-14 for couplers with integrated terminator(s).

Electrical characteristics

PARAMETERS	REQUIRED	ACTUAL
Nominal line impedance*	70 to 84 Ω	77 Ω
Turn ratio	1.41 \pm 3%	1.41 \pm 3%
CMR	< -45 dB at 1 MHz	< -50 dB at 1 MHz
Input impedance	> 1500 Ω in the frequency range (75 kHz to 1 MHz) and in the indicated temp. range (-65°C to 150°C)	> 1500 Ω
Fault protection insulation resistors in series on each bus winding connection	0.75 $Z_o \pm$ 2%	57.6 $\Omega \pm$ 1%
Insulation resistance between:		
- bus / stub	100 M Ω	> 1 000 M Ω at 250 V _{DC}
- inner wires / shield	100 M Ω	> 1 000 M Ω at 500 V _{DC}
Transfer impedance	-	plot available
Shield continuity	-	10 m Ω maximum
Shield coverage	Cable 90% Connection 75%	Cable 90% minimum Connection 100%
Dielectric withstanding strength:		
- between shield and inner wires	500 V _{RMS}	500 V _{RMS}
- between outer insulation and shield	500 V _{RMS}	500 V _{RMS}

* Impedance: seen from the stub when the bus line is loaded with Z_o at both sides of the coupler.

Environmental characteristics

PARAMETERS	REQUIRED	ACTUAL
Operating temperature	-	-65°C to +150°C
Out-gassing	SP-R-0022 - TML < 1% ASTM-E-595 - CVCM < 0.1% ECSS-Q-ST-70-02	TML = 0.0005% RML = 0000027% CVCM = 0%
Off-gassing	NHB 8060.1 Test 7 ECSS-Q-ST-70-29	T = 0.00024 for 65 m ³ volume per coupler* MLW (#) = 2112 for 65 m ³ volume*
MTBF according to MIL HDBK-217	-	2.75 x 10 ⁷ hrs at 25°C and Space Flight environment

Out and Off-gassing results, flammability available for all materials used.

* Typical values obtained by AMB/S-C1 coupler during qualification phase.

Mechanical characteristics

PARAMETERS	REQUIRED	ACTUAL
Weight	-	\leq 16 g
Life test	-	1000 hrs at 120°C
Shocks	-	15 g's in all directions
Acceleration	-	20 g's in all directions
Random vibrations	MIL-STD-810, Method 514.5	Functional at 120°C = 16.35 g RMS Endurance at 20°C = 33.23 g RMS

Other mechanical and environmental tests available on request.

Transformer characteristics

PARAMETERS	REQUIRED VALUES (MIL-STD-1553B or SAE AS-4115)	NOMINAL VALUE OR AXON' REQUIRED VALUE	
		NOMINAL VALUE	REQUIRED BY AXON' / QUALITY PLAN
The Curie point	-	-	Over 195°C
Turn ratio	$\sqrt{2} \pm$ 3%	$\sqrt{2} \pm$ 3%	$\sqrt{2} \pm$ 3%
Secondary DC resistance	$R_s < 5 \Omega$	$R_s = 2 \Omega$	$R_s < 2.5 \Omega$
Insulation resistance (winding to winding)	$R_i > 100 M\Omega$	-	$R_i > 1 000 M\Omega$ with a 250 V _{DC} test voltage
Transformer open circuit impedance	$ Z > 3 k\Omega$ on full temperature operating range	$ Z > 10 k\Omega$ at 25°C $ Z > 4.8 k\Omega$ at -65°C	$ Z > 4 k\Omega$ at -85°C $ Z > 9.4 k\Omega$ at 25°C***
Primary parallel inductance	-	22 mH	> 20 mH
Primary parallel capacitance	-	10 pF	< 11.4 pF
Inter-winding capacitance	-	45 pF	-
Primary leakage inductance	-	-	< 6.0 μ H
Droop*	< 20%	4.5%**	< 20%**
Overshoot and ringing*	$\pm 1 V$	0.30 V**	< $\pm 1 V$ **

* Tested with a 250 kHz square waveform of 27 V_{PP} with 100 ns rise and fall times through a 360 \pm 5% Ω resistor.

** Average values taken during the JN1081N qualification.

*** 9.4 k Ω at 25°C guarantees 3 k Ω from -65°C to +150°C

2 way in-line coupler with terminator

SPECIFICATIONS

Microcoupler
MIL-STD-1553B (STANAG 3838)
SSQ 21676 (NASA-BOEING)
PID (CNES), SPE-J-403-A-0070

Testing
AS-SAE-4115

Resistor
MIL-R-39007

Solder
ECSS-Q-ST-70-08,
MIL-STD-2000, NHB 5300.4.

Derating
ECSS-Q-ST-30-11

Potting material
ECSS-Q-ST-70-02, ASTM E595,
and ECSS-Q-ST-70-29
or NHB 8060.1.

Connector assemblies
ECSS-Q-ST-70-26
or NHB 5300.4.

Transformer
JN1081 approved
DDP-J-403-A-022
ESA approved
(COF-BCS-PAD01)

All processes, materials
and components are
approved by CNES
(see CNES-PID-02-AXON)
and BOEING/NASA.

ESA: European Space Agency
CNES: French Space Agency
PID: Part Identification Document

AMB / S - C2 - XX - T RIGHT 'TR'

Version with bus lines on opposite sides of the coupler.

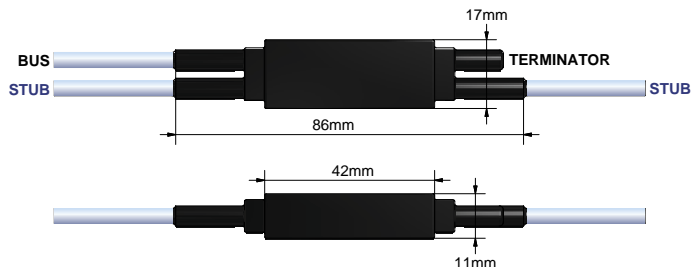

AMB / S - C21 - XX - T LEFT 'TL'

Version with bus lines on same side of the coupler.

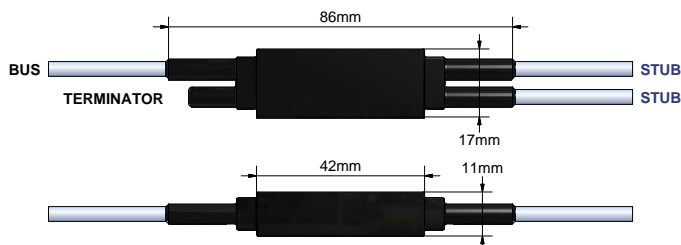

Electrical scheme

$N = 1.41 \pm 3\%$
 $R = \text{fault protection resistance}$
 $R = 0.75 Z_0 = 57.6 \Omega \pm 1\%$

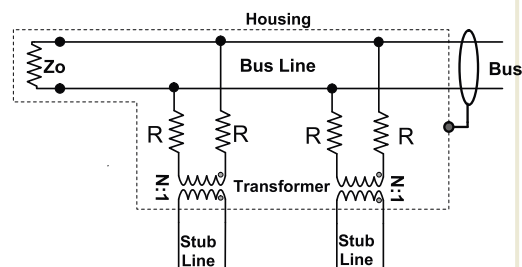

Identification code

AMB /

S

CX

XX

XX

AXON' MICROBUS
(see complete reference of the coupler on Bus Standard sheet, page E-4).

S: SPACE VERSION

2: 2 WAY INLINE COUPLER
Version with bus lines on opposite sides of the coupler.
21: 2 WAY INLINE COUPLER
Version with bus lines on same side of the coupler.

CABLE REFERENCES

40: TWINAX BUS AWG 24 SB (single braid) acc. to SSQ 21655 (NASA qualified).
41: TWINAX BUS AWG 24 DB (double braid).
43: TWINAX BUS AWG 26 SB (single braid).
44: TWINAX BUS AWG 26 DB (double braid).
45: TWINAX BUS AWG 22 SB (single braid) acc. to SSQ 21655 (NASA qualified).
80: TWINAX BUS AWG 24 SB (single braid) according to ESCC 3902.002.20.

TR: T RIGHT
Bus and stub on opposite sides.
TL: T LEFT
Bus and stub on same side of the coupler.

NOTE: CABLE LENGTH AND CABLE COLOUR TO BE DEFINED WHEN ORDERING (possibility to differentiate bus and stub cable with a striped colour tape under the transparent jacket or the extrusion of a colour jacket).
See page E-12 for couplers without integrated terminator(s).

Electrical characteristics

PARAMETERS	REQUIRED	ACTUAL
Nominal line impedance*	70 to 84 Ω	77 Ω
Turn ratio	1.41 \pm 3%	1.41 \pm 3%
CMR	< -45 dB at 1 MHz	< -50 dB at 1 MHz
Terminator impedance	77 Ω \pm 2%	77 Ω \pm 1%
Fault protection insulation resistors in series on each bus winding connection	0.75 Z_o \pm 2%	57.6 Ω \pm 1%
Insulation resistance between:		
- bus / stub	100 M Ω	> 1 000 M Ω at 250 V _{DC}
- inner wires / shield	100 M Ω	> 1 000 M Ω at 500 V _{DC}
Transfer impedance	-	plot available
Shield continuity	-	10 m Ω maximum
Shield coverage	Cable 90% Connection 75%	Cable 90% minimum Connection 100%
Dielectric withstanding strength:		
- between shield and inner wires	500 V _{RMS}	500 V _{RMS}
- between outer insulation and shield	500 V _{RMS}	500 V _{RMS}

* Impedance: seen from the stub when the bus line is loaded with Z_o at both sides of the coupler.

Environmental characteristics

PARAMETERS	REQUIRED	ACTUAL
Operating temperature	-	-65°C to +150°C
Out-gassing	SP-R-0022 - TML < 1% ASTM-E-595 - CVCM < 0.1% ECSS-Q-ST-70-02	TML = 0.0005% RML = 0000027% CVCM = 0%
Off-gassing	NHB 8060.1 Test 7 ECSS-Q-ST-70-29	T = 0.00024 for 65 m ³ volume per coupler* MLW (#) = 2112 for 65 m ³ volume*
MTBF according to MIL HDBK-217	-	2.75 x 10 ⁷ hrs at 25°C and Space Flight environment

Out and Off-gassing results, flammability available for all materials used.

* Typical values obtained by AMB/S-C1 coupler during qualification phase.

Mechanical characteristics

PARAMETERS	REQUIRED	ACTUAL
Weight	-	\leq 18 g
Life test	-	1000 hrs at 120°C
Shocks	-	15 g's in all directions
Acceleration	-	20 g's in all directions
Random vibrations	MIL-STD-810, Method 514.5	Fonctional at 120°C = 16.35 g _{RMS} Endurance at 20°C = 33.23 g _{RMS}

Other mechanical and environmental tests available on request.

Transformer characteristics

PARAMETERS	REQUIRED VALUES (MIL-STD-1553B or SAE AS-4115)	NOMINAL VALUE OR AXON' REQUIRED VALUE	
		NOMINAL VALUE	REQUIRED BY AXON' / QUALITY PLAN
The Curie point	-	-	Over 195°C
Turn ratio	$\sqrt{2} \pm 3\%$	$\sqrt{2} \pm 3\%$	$\sqrt{2} \pm 3\%$
Secondary DC resistance	$R_s < 5 \Omega$	$R_s = 2 \Omega$	$R_s < 2.5 \Omega$
Insulation resistance (winding to winding)	$R_i > 100 M\Omega$	-	$R_i > 1 000 M\Omega$ with a 250 V _{DC} test voltage
Transformer open circuit impedance	$ Z > 3 k\Omega$ on full temperature operating range	$ Z > 10 k\Omega$ at 25°C $ Z > 4.8 k\Omega$ at -65°C	$ Z > 4 k\Omega$ at -85°C $ Z > 9.4 k\Omega$ at 25°C***
Primary parallel inductance	-	22 mH	> 20 mH
Primary parallel capacitance	-	10 pF	< 11.4 pF
Inter-winding capacitance	-	45 pF	-
Primary leakage inductance	-	-	< 6.0 μ H
Droop*	< 20%	4.5%**	< 20%**
Overshoot and ringing*	$\pm 1 V$	0.30 V**	< $\pm 1 V$ **

* Tested with a 250 kHz square waveform of 27 V_{PP} with 100 ns rise and fall times through a 360 \pm 5% Ω resistor.

** Average values taken during the JN1081N qualification.

*** 9.4 k Ω at 25°C guarantees 3 k Ω from -65°C to +150°C

3 way in-line coupler

SPECIFICATIONS

Microcoupler
MIL-STD-1553B (STANAG 3838)
SSQ 21676 (NASA-BOEING)
PID (CNES), SPE-J-403-A-0070

Testing
AS-SAE-4115

Resistor
MIL-R-39007

Solder
ECSS-Q-ST-70-08,
MIL-STD-2000, NHB 5300.4.

Derating
ECSS-Q-ST-30-11

Potting material
ECSS-Q-ST-70-02, ASTM E595,
and ECSS-Q-ST-70-29
or NHB 8060.1.

Connector assemblies
ECSS-Q-ST-70-26
or NHB 5300.4.

Transformer
JN1081 approved
DDP-J-403-A-022
ESA approved
(COF-BCS-PAD01)

All processes, materials
and components are
approved by CNES
(see CNES-PID-02-AXON*)
and BOEING/NASA.

ESA: European Space Agency
CNES: French Space Agency
PID: Part Identification Document

AMB / S - C3 - XX

Version with bus lines on opposite sides of the coupler.

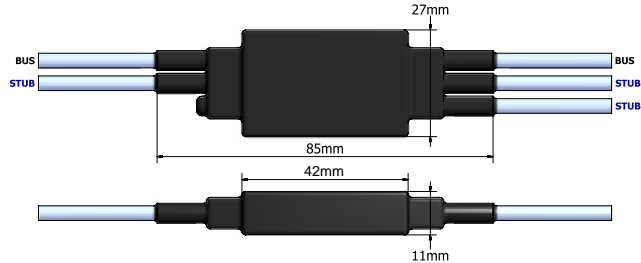

AMB / S - C31 - XX

Version with bus lines on same side of the coupler.

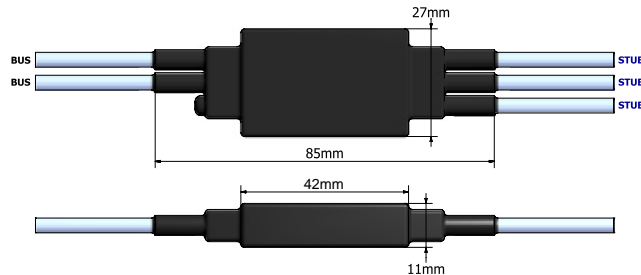

Electrical scheme

$$N = 1.41 \pm 3\%$$

R = fault protection resistance

$$R = 0.75 Z_0 = 57.6 \Omega \pm 1\%$$

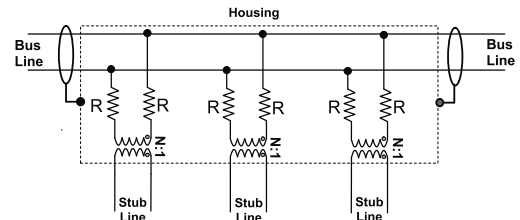

Identification code

AMB /

S

CX

XX

AXON[®] MICROBUS
(see complete reference of the coupler on Bus Standard sheet, page E-4).

S: SPACE VERSION

3: 3 WAY IN-LINE COUPLER
Version with bus lines on opposite sides of the coupler.
31: 3 WAY IN-LINE COUPLER
Version with bus lines on same side of the coupler.

CABLE REFERENCES

40: TWINAX BUS AWG 24 SB (single braid) acc. to SSQ 21655 (NASA qualified).
41: TWINAX BUS AWG 24 DB (double braid).
43: TWINAX BUS AWG 26 SB (single braid).
44: TWINAX BUS AWG 26 DB (double braid).
45: TWINAX BUS AWG 22 SB (single braid) acc. to SSQ 21655 (NASA qualified).
80: TWINAX BUS AWG 24 SB (single braid) according to ESCC 3902.002.20.

NOTE: CABLE LENGTH AND CABLE COLOUR TO BE DEFINED WHEN ORDERING (possibility to differentiate bus and stub cable with a striped colour tape under the transparent jacket or the extrusion of a colour jacket).
See page E-18 for couplers with integrated terminator(s).

Electrical characteristics

PARAMETERS	REQUIRED	ACTUAL
Nominal line impedance*	70 to 84 Ω	77 Ω
Turn ratio	1.41 \pm 3%	1.41 \pm 3%
CMR	< -45 dB at 1 MHz	< -50 dB at 1 MHz
Input impedance	> 1000 Ω in the frequency range (75 kHz to 1 MHz) and in the indicated temp. range (-65°C to 150°C)	> 1000 Ω
Fault protection insulation resistors in series on each bus winding connection	0.75 $Z_0 \pm$ 2%	57.6 $\Omega \pm$ 1%
Insulation resistance between:		
- bus / stub	100 M Ω	> 1 000 M Ω at 250 V _{DC}
- inner wires / shield	100 M Ω	> 1 000 M Ω at 500 V _{DC}
Transfer impedance	-	plot available
Shield continuity	-	10 m Ω maximum
Shield coverage	Cable 90% Connection 75%	Cable 90% minimum Connection 100%
Dielectric withstanding strength:		
- between shield and inner wires	500 V _{RMS}	500 V _{RMS}
- between outer insulation and shield	500 V _{RMS}	500 V _{RMS}

* Impedance: seen from the stub when the bus line is loaded with Z_0 at both sides of the coupler.

Environmental characteristics

PARAMETERS	REQUIRED	ACTUAL
Operating temperature	-	-65°C to +150°C
Out-gassing	SP-R-0022 - TML < 1% ASTM-E-595 - CVCM < 0.1% ECSS-Q-ST-70-02	TML = 0.0005% RML = 0000027% CVCM = 0%
Off-gassing	NHB 8060.1 Test 7 ECSS-Q-ST-70-29	T = 0.00024 for 65 m ³ volume per coupler* MLW (#) = 2112 for 65 m ³ volume*
MTBF according to MIL HDBK-217	-	1.87 x 10 ⁷ hrs at 25°C and Space Flight environment

Out and Off-gassing results, flammability available for all materials used.

* Typical values obtained by AMB/S-C1 coupler during qualification phase.

Mechanical characteristics

PARAMETERS	REQUIRED	ACTUAL
Weight	-	\leq 25 g
Life test	-	1000 hrs at 120°C
Shocks	-	15 g's in all directions
Acceleration	-	20 g's in all directions
Random vibrations	MIL-STD-810, Method 514.5	Fonctional at 120°C = 16.35 g _{RMS} Endurance at 20°C = 33.23 g _{RMS}

Other mechanical and environmental tests available on request.

Transformer characteristics

PARAMETERS	REQUIRED VALUES (MIL-STD-1553B or SAE AS-4115)	NOMINAL VALUE OR AXON' REQUIRED VALUE	
		NOMINAL VALUE	REQUIRED BY AXON' / QUALITY PLAN
The Curie point	-	-	Over 195°C
Turn ratio	$\sqrt{2} \pm$ 3%	$\sqrt{2} \pm$ 3%	$\sqrt{2} \pm$ 3%
Secondary DC resistance	$R_s < 5 \Omega$	$R_s = 2 \Omega$	$R_s < 2.5 \Omega$
Insulation resistance (winding to winding)	$R_i > 100 M\Omega$	-	$R_i > 1 000 M\Omega$ with a 250 V _{DC} test voltage
Transformer open circuit impedance	$ Z > 3 k\Omega$ on full temperature operating range	$ Z > 10 k\Omega$ at 25°C $ Z > 4.8 k\Omega$ at -65°C	$ Z > 4 k\Omega$ at -85°C $ Z > 9.4 k\Omega$ at 25°C***
Primary parallel inductance	-	22 mH	> 20 mH
Primary parallel capacitance	-	10 pF	< 11.4 pF
Inter-winding capacitance	-	45 pF	-
Primary leakage inductance	-	-	< 6.0 μ H
Droop*	< 20%	4.5%**	< 20%**
Overshoot and ringing*	\pm 1 V	0.30 V**	< \pm 1 V**

* Tested with a 250 kHz square waveform of 27 V_{PP} with 100 ns rise and fall times through a 360 \pm 5% Ω resistor.

** Average values taken during the JN1081N qualification.

*** 9.4 k Ω at 25°C guarantees 3 k Ω from -65°C to +150°C

3 way in-line coupler with terminator

SPECIFICATIONS

Microcoupler
MIL-STD-1553B (STANAG 3838)
SSQ 21676 (NASA-BOEING)
PID (CNES), SPE-J-403-A-0070

Testing
AS-SAE-4115

Resistor
MIL-R-39007

Solder
ECSS-Q-ST-70-08,
MIL-STD-2000, NHB 5300.4.

Derating
ECSS-Q-ST-30-11

Potting material
ECSS-Q-ST-70-02, ASTM E595,
and ECSS-Q-ST-70-29
or NHB 8060.1.

Connector assemblies
ECSS-Q-ST-70-26
or NHB 5300.4.

Transformer
JN1081 approved
DDP-J-403-A-022
ESA approved
(COF-BCS-PAD01)

All processes, materials
and components are
approved by CNES
(see CNES-PID-02-AXON*)
and BOEING/NASA.

ESA: European Space Agency
CNES: French Space Agency
PID: Part Identification Document

AMB / S - C3 - XX - T RIGHT 'TR'

Version with bus lines on opposite sides of the coupler.

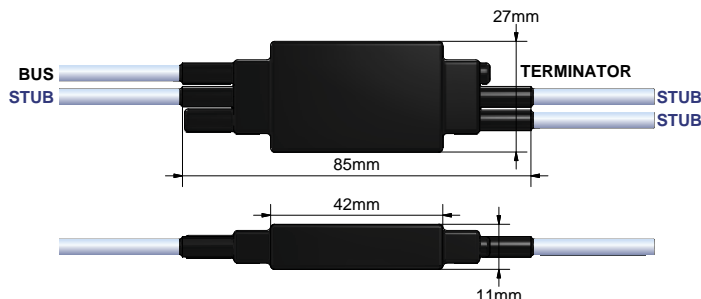

AMB / S - C31 - XX - T LEFT 'TL'

Version with bus lines on same side of the coupler.

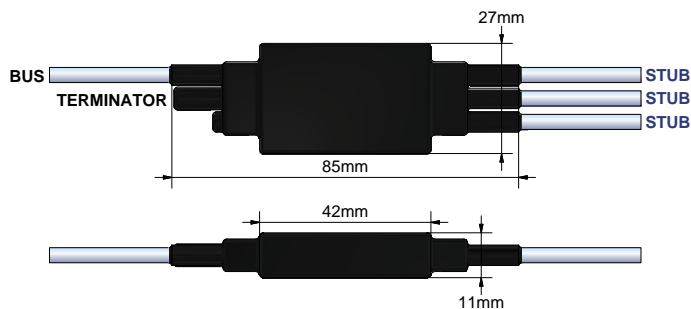

Electrical scheme

$N = 1.41 \pm 3\%$

$R = \text{fault protection resistance}$

$R = 0.75 Z_0 = 57.6 \Omega \pm 1\%$

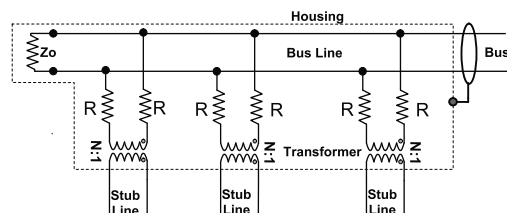

Identification code

AMB /

S

CX

XX

XX

AXON' MICROBUS
(see complete reference of the coupler on Bus Standard sheet, page E-4).

S: SPACE VERSION

3: 3 WAY IN-LINE COUPLER
Version with bus lines on opposite sides of the coupler.
31: 3 WAY IN-LINE COUPLER
Version with bus lines on same side of the coupler.

CABLE REFERENCES

40: TWINAX BUS AWG 24 SB (single braid) acc. to SSQ 21655 (NASA qualified).
41: TWINAX BUS AWG 24 DB (double braid).
43: TWINAX BUS AWG 26 SB (single braid).
44: TWINAX BUS AWG 26 DB (double braid).
45: TWINAX BUS AWG 22 SB (single braid) acc. to SSQ 21655 (NASA qualified).
80: TWINAX BUS AWG 24 SB (single braid) according to ESCC 3902.002.20.

TR: T RIGHT
Bus and stub on opposite sides.
TL: T LEFT
Bus and stub on same side of the coupler.

NOTE: CABLE LENGTH AND CABLE COLOUR TO BE DEFINED WHEN ORDERING (possibility to differentiate bus and stub cable with a striped colour tape under the transparent jacket or the extrusion of a colour jacket).
See page E-16 for couplers without integrated terminator(s).

Electrical characteristics

PARAMETERS	REQUIRED	ACTUAL
Nominal line impedance*	70 to 84 Ω	77 Ω
Turn ratio	1.41 $\pm 3\%$	1.41 $\pm 3\%$
CMR	< -45 dB at 1 MHz	< -50 dB at 1 MHz
Terminator impedance	77 $\Omega \pm 2\%$	77 $\Omega \pm 1\%$
Fault protection insulation resistors in series on each bus winding connection	0.75 $Z_0 \pm 2\%$	57.6 $\Omega \pm 1\%$
Insulation resistance between:		
- bus / stub	100 M Ω	> 1 000 M Ω at 250 V _{DC}
- inner wires / shield	100 M Ω	> 1 000 M Ω at 500 V _{DC}
Transfer impedance	-	plot available
Shield continuity	-	10 m Ω maximum
Shield coverage	Cable 90% Connection 75%	Cable 90% minimum Connection 100%
Dielectric withstanding strength:		
- between shield and inner wires	500 V _{RMS}	500 V _{RMS}
- between outer insulation and shield	500 V _{RMS}	500 V _{RMS}

* Impedance: seen from the stub when the bus line is loaded with Z_0 at both sides of the coupler.

Environmental characteristics

PARAMETERS	REQUIRED	ACTUAL
Operating temperature	-	-65°C to +150°C
Out-gassing	SP-R-0022 - TML < 1% ASTM-E-595 - CVCM < 0.1% ECSS-Q-ST-70-02	TML = 0.0005% RML = 0000027% CVCM = 0%
Off-gassing	NHB 8060.1 Test 7 ECSS-Q-ST-70-29	T = 0.00024 for 65 m ³ volume per coupler* MLW (#) = 2112 for 65 m ³ volume*
MTBF according to MIL HDBK-217	-	1.87 x 10 ⁷ hrs at 25°C and Space Flight environment

Out and Off-gassing results, flammability available for all materials used.

* Typical values obtained by AMB/S-C1 coupler during qualification phase.

Mechanical characteristics

PARAMETERS	REQUIRED	ACTUAL
Weight	-	≤ 27 g
Life test	-	1000 hrs at 120°C
Shocks	-	15 g's in all directions
Acceleration	-	20 g's in all directions
Random vibrations	MIL-STD-810, Method 514.5	Functional at 120°C = 16.35 g _{RMS} Endurance at 20°C = 33.23 g _{RMS}

Other mechanical and environmental tests available on request.

Transformer characteristics

PARAMETERS	REQUIRED VALUES (MIL-STD-1553B or SAE AS-4115)	NOMINAL VALUE OR AXON' REQUIRED VALUE	
		NOMINAL VALUE	REQUIRED BY AXON' / QUALITY PLAN
The Curie point	-	-	Over 195°C
Turn ratio	$\sqrt{2} \pm 3\%$	$\sqrt{2} \pm 3\%$	$\sqrt{2} \pm 3\%$
Secondary DC resistance	$R_s < 5 \Omega$	$R_s = 2 \Omega$	$R_s < 2.5 \Omega$
Insulation resistance (winding to winding)	$R_i > 100 \text{ M}\Omega$	-	$R_i > 1 000 \text{ M}\Omega$ with a 250 V _{DC} test voltage
Transformer open circuit impedance	$ Z > 3 \text{ k}\Omega$ on full temperature operating range	$ Z > 10 \text{ k}\Omega$ at 25°C $ Z > 4.8 \text{ k}\Omega$ at -65°C	$ Z > 4 \text{ k}\Omega$ at -85°C $ Z > 9.4 \text{ k}\Omega$ at 25°C***
Primary parallel inductance	-	22 mH	> 20 mH
Primary parallel capacitance	-	10 pF	< 11.4 pF
Inter-winding capacitance	-	45 pF	-
Primary leakage inductance	-	-	< 6.0 μH
Droop*	< 20%	4.5%**	< 20%**
Overshoot and ringing*	± 1 V	0.30 V**	< ± 1 V**

* Tested with a 250 kHz square waveform of 27 V_{PP} with 100 ns rise and fall times through a 360 $\pm 5\%$ Ω resistor.

** Average values taken during the JN1081N qualification.

*** 9.4 k Ω at 25°C guarantees 3 k Ω from -65°C to +150°C

4 way in-line coupler

SPECIFICATIONS

Microcoupler
MIL-STD-1553B (STANAG 3838)
SSQ 21676 (NASA-BOEING)
PID (CNES), SPE-J-403-A-0070

Testing
AS-SAE-4115

Resistor
MIL-R-39007

Solder
ECSS-Q-ST-70-08,
MIL-STD-2000, NHB 5300.4.

Derating
ECSS-Q-ST-30-11

Potting material
ECSS-Q-ST-70-02, ASTM E595,
and ECSS-Q-ST-70-29
or NHB 8060.1.

Connector assemblies
ECSS-Q-ST-70-26
or NHB 5300.4.

Transformer
JN1081 approved
DDP-J-403-A-022
ESA approved
(COF-BCS-PAD01)

All processes, materials
and components are
approved by CNES
(see CNES-PID-02-AXON*)
and BOEING/NASA.

ESA: European Space Agency
CNES: French Space Agency
PID: Part Identification Document

AMB / S - C4 - XX

Version with bus lines on opposite sides of the coupler.

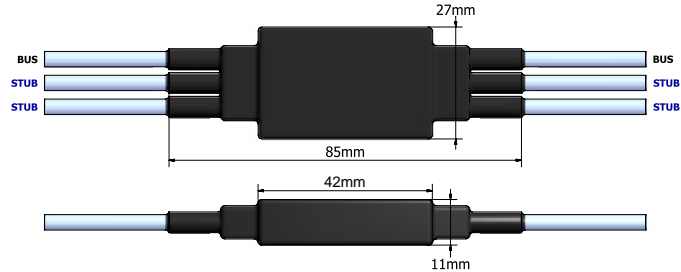

AMB / S - C41 - XX

Version with bus lines on same side of the coupler.

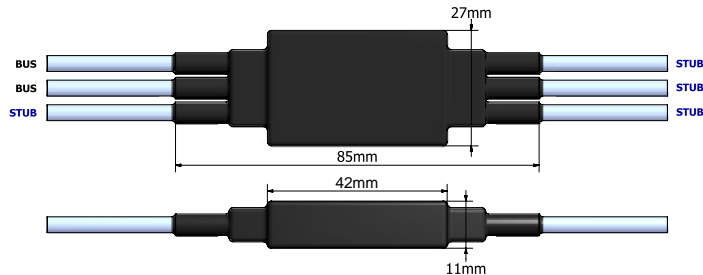

Electrical scheme

$N = 1.41 \pm 3\%$
 $R = \text{fault protection resistance}$
 $R = 0.75 Z_0 = 57.6 \Omega \pm 1\%$

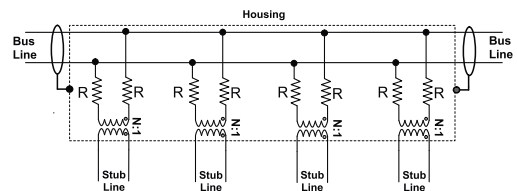

Identification code

AMB /

S

CX

XX

**AXON'
MICROBUS**
(see complete
reference of
the coupler
on Bus
Standard
sheet, page
E-4).

**S: SPACE
VERSION**

4: 4 WAY IN-LINE COUPLER
Version with bus lines on
opposite sides of the coupler.
41: 4 WAY IN-LINE COUPLER
Version with bus lines on
same side of the coupler.

CABLE REFERENCES

40: TWINAX BUS AWG 24 SB (single braid) acc. to SSQ 21655 (NASA qualified).
41: TWINAX BUS AWG 24 DB (double braid).
43: TWINAX BUS AWG 26 SB (single braid).
44: TWINAX BUS AWG 26 DB (double braid).
45: TWINAX BUS AWG 22 SB (single braid) acc. to SSQ 21655 (NASA qualified).
80: TWINAX BUS AWG 24 SB (single braid) according to ESCC 3902.002.20.

NOTE: CABLE LENGTH AND CABLE COLOUR TO BE DEFINED WHEN ORDERING (possibility to differentiate bus and stub cable with a striped colour tape under the transparent jacket or the extrusion of a colour jacket).
See page E-22 for couplers with integrated terminator(s).

Electrical characteristics

PARAMETERS	REQUIRED	ACTUAL
Nominal line impedance*	70 to 84 Ω	77 Ω
Turn ratio	1.41 \pm 3%	1.41 \pm 3%
CMR	< -45 dB at 1 MHz	< -50 dB at 1 MHz
Input impedance	> 750 Ω in the frequency range (75 kHz to 1 MHz) and in the indicated temp. range (-65°C to 150°C)	> 750 Ω
Fault protection insulation resistors in series on each bus winding connection	0.75 $Z_0 \pm$ 2%	57.6 $\Omega \pm$ 1%
Insulation resistance between:		
- bus / stub	100 M Ω	> 1 000 M Ω at 250 V _{DC}
- inner wires / shield	100 M Ω	> 1 000 M Ω at 500 V _{DC}
Transfer impedance	-	plot available
Shield continuity	-	10 m Ω maximum
Shield coverage	Cable 90% Connection 75%	Cable 90% minimum Connection 100%
Dielectric withstanding strength:		
- between shield and inner wires	-	500 V _{RMS}
- between outer insulation and shield	-	500 V _{RMS}

* Impedance: seen from the stub when the bus line is loaded with Z_0 at both sides of the coupler.

Environmental characteristics

PARAMETERS	REQUIRED	ACTUAL
Operating temperature	-	-65°C to +150°C
Out-gassing	SP-R-0022 - TML < 1% ASTM-E-595 - CVCM < 0.1% ECSS-Q-ST-70-02	TML = 0.0005% RML = 0000027% CVCM = 0%
Off-gassing	NHB 8060.1 Test 7 ECSS-Q-ST-70-29	T = 0.00024 for 65 m ³ volume per coupler* MLW (#) = 2112 for 65 m ³ volume*
MTBF according to MIL HDBK-217	-	1.41 x 10 ⁷ hrs at 25°C and Space Flight environment

Out and Off-gassing results, flammability available for all materials used.

* Typical values obtained by AMB/S-C1 coupler during qualification phase.

Mechanical characteristics

PARAMETERS	REQUIRED	ACTUAL
Weight	-	\leq 25 g
Life test	-	1000 hrs at 120°C
Shocks	-	15 g's in all directions
Acceleration	-	20 g's in all directions
Random vibrations	MIL-STD-810, Method 514.5	Functional at 120°C = 16.35 g _{RMS} Endurance at 20°C = 33.23 g _{RMS}

Other mechanical and environmental tests available on request.

Transformer characteristics

PARAMETERS	REQUIRED VALUES (MIL-STD-1553B or SAE AS-4115)	NOMINAL VALUE OR AXON' REQUIRED VALUE	
		NOMINAL VALUE	REQUIRED BY AXON' / QUALITY PLAN
The Curie point	-	-	Over 195°C
Turn ratio	$\sqrt{2} \pm$ 3%	$\sqrt{2} \pm$ 3%	$\sqrt{2} \pm$ 3%
Secondary DC resistance	$R_s < 5 \Omega$	$R_s = 2 \Omega$	$R_s < 2.5 \Omega$
Insulation resistance (winding to winding)	$R_i > 100 M\Omega$	-	$R_i > 1 000 M\Omega$ with a 250 V _{DC} test voltage
Transformer open circuit impedance	$ Z > 3 k\Omega$ on full temperature operating range	$ Z > 10 k\Omega$ at 25°C $ Z > 4.8 k\Omega$ at -65°C	$ Z > 4 k\Omega$ at -85°C $ Z > 9.4 k\Omega$ at 25°C***
Primary parallel inductance	-	22 mH	> 20 mH
Primary parallel capacitance	-	10 pF	< 11.4 pF
Inter-winding capacitance	-	45 pF	-
Primary leakage inductance	-	-	< 6.0 μ H
Droop*	< 20%	4.5%**	< 20%**
Overshoot and ringing*	$\pm 1 V$	0.30 V**	< $\pm 1 V^{**}$

* Tested with a 250 kHz square waveform of 27 V_{PP} with 100 ns rise and fall times through a 360 \pm 5% Ω resistor.

** Average values taken during the JN1081N qualification.

*** 9.4 k Ω at 25°C guarantees 3 k Ω from -65°C to +150°C

4 way in-line coupler with terminator

SPECIFICATIONS

Microcoupler
MIL-STD-1553B (STANAG 3838)
SSQ 21676 (NASA-BOEING)
PID (CNES), SPE-J-403-A-0070

Testing
AS-SAE-4115

Resistor
MIL-R-39007

Solder
ECSS-Q-ST-70-08,
MIL-STD-2000, NHB 5300.4.

Derating
ECSS-Q-ST-30-11

Potting material
ECSS-Q-ST-70-02, ASTM E595,
and ECSS-Q-ST-70-29
or NHB 8060.1.

Connector assemblies
ECSS-Q-ST-70-26
or NHB 5300.4.

Transformer
JN1081 approved
DDP-J-403-A-022
ESA approved
(COF-BCS-PAD01)

All processes, materials
and components are
approved by CNES
(see CNES-PID-02-AXON)
and BOEING/NASA.

ESA: European Space Agency
CNES: French Space Agency
PID: Part Identification Document

AMB / S - C4 - XX - T RIGHT 'TR'

Version with bus lines on opposite sides of the coupler.

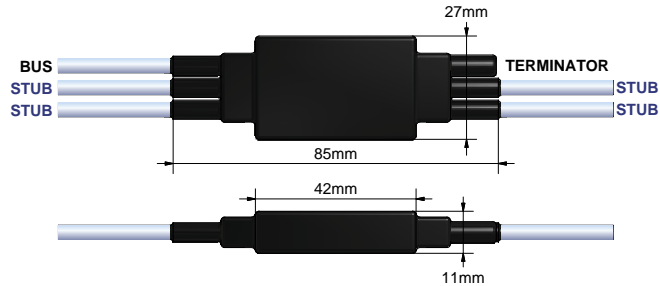

AMB / S - C41 - XX - T LEFT 'TL'

Version with bus lines on same side of the coupler.

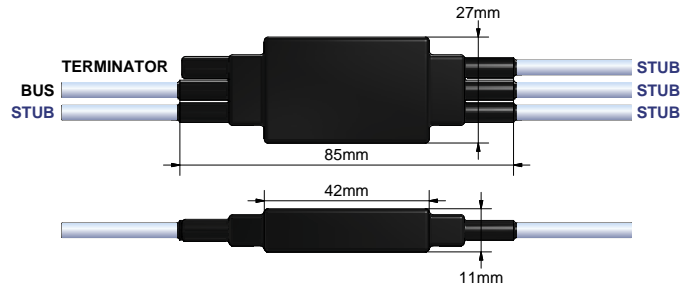

Electrical scheme

$N = 1.41 \pm 3\%$

$R = \text{fault protection resistance}$

$R = 0.75 Z_0 = 57.6 \Omega \pm 1\%$

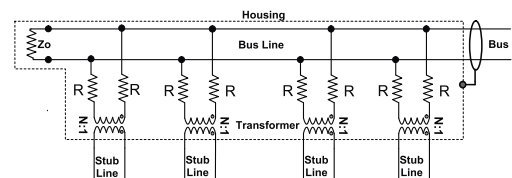

Identification code

AMB /

S

CX

XX

TX

AXON' MICROBUS
(see complete reference of the coupler on Bus Standard sheet, page E-4).

S: SPACE VERSION

4: 4 WAY IN-LINE COUPLER
Version with bus lines on opposite sides of the coupler.
41: 4 WAY IN-LINE COUPLER
Version with bus lines on same side of the coupler.

CABLE REFERENCES

40: TWINAX BUS AWG 24 SB (single braid) acc. to SSQ 21655 (NASA qualified).
41: TWINAX BUS AWG 24 DB (double braid).
43: TWINAX BUS AWG 26 SB (single braid).
44: TWINAX BUS AWG 26 DB (double braid).
45: TWINAX BUS AWG 22 SB (single braid) acc. to SSQ 21655 (NASA qualified).
80: TWINAX BUS AWG 24 SB (single braid) according to ESCC 3902.002.20.

TR: T RIGHT
Bus and stub on opposite sides.
TL: T LEFT
Bus and stub on same side of the coupler.

NOTE: CABLE LENGTH AND CABLE COLOUR TO BE DEFINED WHEN ORDERING (possibility to differentiate bus and stub cable with a striped colour tape under the transparent jacket or the extrusion of a colour jacket).
See page E-20 for couplers without integrated terminator(s).

Electrical characteristics

PARAMETERS	REQUIRED	ACTUAL
Nominal line impedance*	70 to 84 Ω	77 Ω
Turn ratio	1.41 \pm 3%	1.41 \pm 3%
CMR	< -45 dB at 1 MHz	< -50 dB at 1 MHz
Terminator impedance	77 Ω \pm 2%	77 Ω \pm 1%
Fault protection insulation resistors in series on each bus winding connection	0.75 Z_0 \pm 2%	57.6 Ω \pm 1%
Insulation resistance between:		
- bus / stub	100 M Ω	> 1 000 M Ω at 250 V _{DC}
- inner wires / shield	100 M Ω	> 1 000 M Ω at 500 V _{DC}
Transfer impedance	-	plot available
Shield continuity	-	10 m Ω maximum
Shield coverage	Cable 90% Connection 75%	Cable 90% minimum Connection 100%
Dielectric withstanding strength:		
- between shield and inner wires	-	500 V _{RMS}
- between outer insulation and shield	-	500 V _{RMS}

* Impedance: seen from the stub when the bus line is loaded with Z_0 at both sides of the coupler.

Environmental characteristics

PARAMETERS	REQUIRED	ACTUAL
Operating temperature	-	-65°C to +150°C
Out-gassing	SP-R-0022 - TML < 1% ASTM-E-595 - CVCM < 0.1% ECSS-Q-ST-70-02	TML = 0.0005% RML = 0000027% CVCM = 0%
Off-gassing	NHB 8060.1 Test 7 ECSS-Q-ST-70-29	T = 0.00024 for 65 m ³ volume per coupler* MLW (#) = 2112 for 65 m ³ volume*
MTBF according to MIL HDBK-217	-	1.41 x 10 ⁷ hrs at 25°C and Space Flight environment

Out and Off-gassing results, flammability available for all materials used.

* Typical values obtained by AMB/S-C1 coupler during qualification phase.

Mechanical characteristics

PARAMETERS	REQUIRED	ACTUAL
Weight	-	\leq 27 g
Life test	-	1000 hrs at 120°C
Shocks	-	15 g's in all directions
Acceleration	-	20 g's in all directions
Random vibrations	MIL-STD-810, Method 514.5	Functional at 120°C = 16.35 g _{RMS} Endurance at 20°C = 33.23 g _{RMS}

Other mechanical and environmental tests available on request.

Transformer characteristics

PARAMETERS	REQUIRED VALUES (MIL-STD-1553B or SAE AS-4115)	NOMINAL VALUE OR AXON' REQUIRED VALUE	
		NOMINAL VALUE	REQUIRED BY AXON' / QUALITY PLAN
The Curie point	-	-	Over 195°C
Turn ratio	$\sqrt{2} \pm 3\%$	$\sqrt{2} \pm 3\%$	$\sqrt{2} \pm 3\%$
Secondary DC resistance	$R_s < 5 \Omega$	$R_s = 2 \Omega$	$R_s < 2.5 \Omega$
Insulation resistance (winding to winding)	$R_i > 100 M\Omega$	-	$R_i > 1 000 M\Omega$ with a 250 V _{DC} test voltage
Transformer open circuit impedance	$ Z_I > 3 k\Omega$ on full temperature operating range	$ Z_I > 10 k\Omega$ at 25°C $ Z_I > 4.8 k\Omega$ at -65°C	$ Z_I > 4 k\Omega$ at -85°C $ Z_I > 9.4 k\Omega$ at 25°C***
Primary parallel inductance	-	22 mH	> 20 mH
Primary parallel capacitance	-	10 pF	< 11.4 pF
Inter-winding capacitance	-	45 pF	-
Primary leakage inductance	-	-	< 6.0 μ H
Droop*	< 20%	4.5%**	< 20%**
Overshoot and ringing*	± 1 V	0.30 V**	< ± 1 V**

* Tested with a 250 kHz square waveform of 27 V_{PP} with 100 ns rise and fall times through a 360 \pm 5% Ω resistor.

** Average values taken during the JN1081N qualification.

*** 9.4 k Ω at 25°C guarantees 3 k Ω from -65°C to +150°C

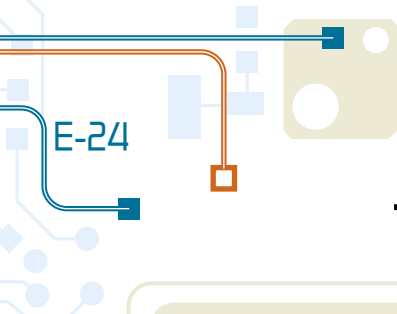

1 way in-line direct coupler

SPECIFICATIONS

MIL-STD-1553B
STANAG 3838
SAE AS4115

AMBD / S - C1 - XX

Bus and stub can be placed anywhere as long as there are two bus lines and one stub line.

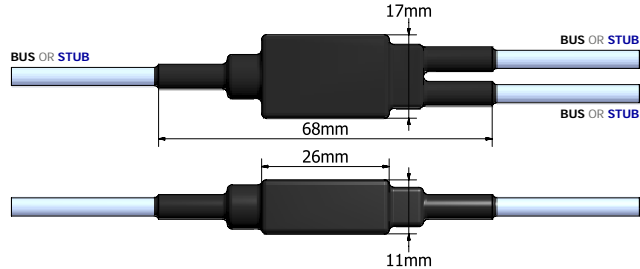

Electrical scheme

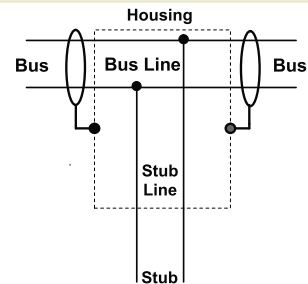

Identification code

AMBD /

S

C1

XX

AXON'
MICROBUS
DIRECT
COUPLER

S : SPACE
VERSION

1 : 1 WAY IN-LINE DIRECT
COUPLER

CABLE REFERENCES

- 40: TWINAX BUS AWG 24 SB (single braid) acc. to SSQ 21655 (NASA qualified).
- 41: TWINAX BUS AWG 24 DB (double braid).
- 43: TWINAX BUS AWG 26 SB (single braid).
- 44: TWINAX BUS AWG 26 DB (double braid).
- 45: TWINAX BUS AWG 22 SB (single braid) acc. to SSQ 21655 (NASA qualified).
- 80: TWINAX BUS AWG 24 SB (single braid) according to ESCC 3902.002.20.

NOTE: CABLE LENGTH AND CABLE COLOUR TO BE DEFINED WHEN ORDERING (possibility to differentiate bus and stub cable with a striped colour tape under the transparent jacket or the extrusion of a colour jacket).

Electrical characteristics

PARAMETERS	REQUIRED	ACTUAL
Nominal line impedance*	70 to 84 Ω	77 Ω
Turn ratio	1.41 \pm 3%	1.41 \pm 3%
CMR	< -45 dB at 1 MHz	< -50 dB at 1 MHz
Input impedance	> 1500 Ω in the frequency range (75 kHz to 1 MHz) and in the indicated temp. range (-65°C to 150°C)	> 1500 Ω
Fault protection insulation resistors in series on each bus winding connection	0.75 $Z_0 \pm$ 2%	57.6 $\Omega \pm$ 1%
Stub line bleed off resistor		2 M $\Omega \pm$ 2%
Insulation resistance between:		
- bus / stub	100 M Ω	> 1 000 M Ω at 250 V _{DC}
- bus / shield	100 M Ω	> 1 000 M Ω at 500 V _{DC}
Transfer impedance	-	plot available
Shield continuity	-	10 m Ω maximum
Shield coverage	Cable 90% Connection 75%	Cable 90% minimum Connection 100%
Dielectric withstanding strength:		
- between shield and bus line	500 V _{RMS}	500 V _{RMS}
- between outer insulation and shield	500 V _{RMS}	500 V _{RMS}

* Impedance: seen from the stub when the bus line is loaded with Z_0 at both sides of the coupler.

Environmental characteristics

PARAMETERS	REQUIRED	ACTUAL
Operating temperature	-	-65°C to +150°C
Out-gassing	SP-R-0022 - TML < 1% ASTM-E-595 - CVCM < 0.1% ECSS-Q-ST-70-02	TML = 0.0005% RML = 0000027% CVCM = 0%
Off-gassing	NHB 8060.1 Test 7 ECSS-Q-ST-70-29	T = 0.00024 for 65 m ³ volume per coupler* MLW (#) = 2112 for 65 m ³ volume*
MTBF according to MIL HDBK-217	-	1.78 x 10 ⁸ at 25°C and Space Flight environment

Out and Off-gassing results, flammability available for all materials used.

* Typical values obtained by AMB/S-C1 coupler during qualification phase.

1 way in-line ESD coupler

SPECIFICATIONS

Microcoupler
MIL-STD-1553B (STANAG 3838)
SSQ 21676 (NASA-BOEING)
PID (CNES), SPE-J-403-A-0070

Testing
AS-SAE-4115

Resistor
MIL-R-39007
MIL-PRF-39017

Solder
ECSS-Q-ST-70-08,
MIL-STD-2000, NHB 5300.4.

Derating
ECSS-Q-ST-30-11

Potting material
ECSS-Q-ST-70-02, ASTM E595,
and ECSS-Q-ST-70-29
or NHB 8060.1.

Connector assemblies
ECSS-Q-ST-70-26
or NHB 5300.4.

Transformer
JN1081 approved
DDP-J-403-A-022
ESA approved
(COF-BCS-PAD01)

All processes, materials
and components are
approved by CNES
(see CNES-PID-02-AXON')
and BOEING/NASA.

ESA: European Space Agency
CNES: French Space Agency
PID: Part Identification Document

AMB / S - C1 - XX - X ESD

Version with bus lines on opposite sides of the coupler.

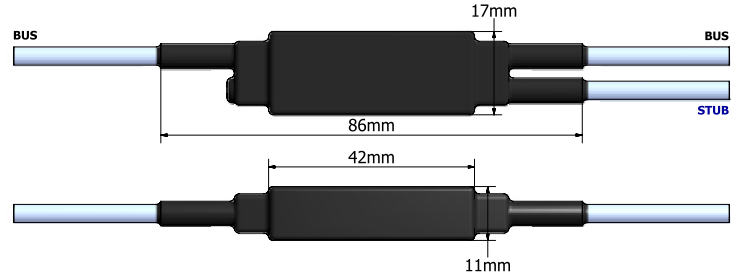

AMB / S - C11 - XX - X ESD

Version with bus lines on same side of the coupler.

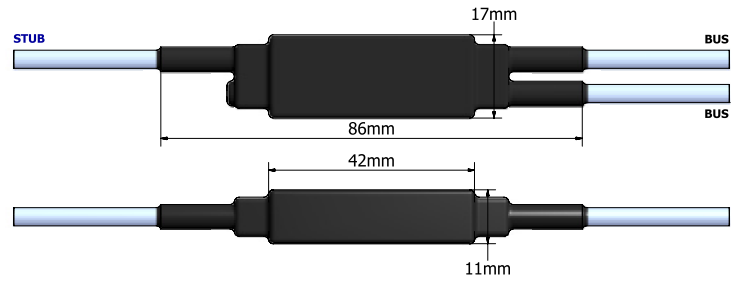

Electrical scheme

$N = 1.41 \pm 3\%$
 $R = \text{fault protection resistance}$
 $R = 0.75 Z_0 = 57.6 \Omega \pm 1\%$
 $R_{ESD} = 2 \text{ M}\Omega$

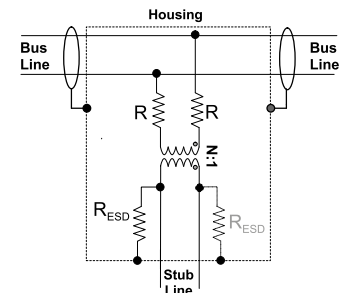

Possibility to have 1 or 2 bleed off resistors of 2 M Ω for each stub line.

Identification code

AMB /

S

CX

XX

X ESD

AXON'
MICROBUS

S: SPACE
VERSION

1: 1 WAY IN-LINE COUPLER
Version with bus lines on
opposite sides of the coupler.

CABLE REFERENCES

- 40: TWINAX BUS AWG 24 SB (single braid) according to SSQ 21655 (NASA qualified).
- 41: TWINAX BUS AWG 24 DB (double braid).
- 43: TWINAX BUS AWG 26 SB (single braid).
- 44: TWINAX BUS AWG 26 DB (double braid).
- 45: TWINAX BUS AWG 22 SB (single braid) according to SSQ 21655 (NASA qualified).
- 80: TWINAX BUS AWG 24 SB (single braid) according to ESCC 3902.002.20.

- 1: One bleed off resistor for each stub line.
- 2: Two bleed off resistors for each stub line.

NOTE: CABLE LENGTH AND CABLE COLOUR TO BE DEFINED WHEN ORDERING (possibility to differentiate bus and stub cable with a striped colour tape under the transparent jacket or the extrusion of a colour jacket).

Electrical characteristics

PARAMETERS	REQUIRED	ACTUAL
Nominal line impedance*	70 to 84 Ω	77 Ω
Turn ratio	1.41 \pm 3%	1.41 \pm 3%
CMR	< -45 dB at 1 MHz	< -50 dB at 1 MHz
Input impedance	> 3000 Ω in the frequency range (75 kHz to 1 MHz) and in the indicated temp. range (-65°C to 150°C)	> 3000 Ω
Fault protection insulation resistors in series on each bus winding connection	0.75 $Z_0 \pm$ 2%	57.6 $\Omega \pm$ 1%
Stub line bleed off resistor		2 M $\Omega \pm$ 2%
Insulation resistance between:		
- bus / stub	100 M Ω	> 1 000 M Ω at 250 V _{DC}
- bus / shield	100 M Ω	> 1 000 M Ω at 500 V _{DC}
Transfer impedance	-	plot available
Shield continuity	-	10 m Ω maximum
Shield coverage	Cable 90% Connection 75%	Cable 90% minimum Connection 100%
Dielectric withstanding strength:		
- between shield and bus line	500 V _{RMS}	500 V _{RMS}
- between outer insulation and shield	500 V _{RMS}	500 V _{RMS}

* Impedance: seen from the stub when the bus line is loaded with Z_0 at both sides of the coupler.

Environmental characteristics

PARAMETERS	REQUIRED	ACTUAL
Operating temperature	-	-65°C to +150°C
Out-gassing	SP-R-0022 - TML < 1% ASTM-E-595 - CVCM < 0.1% ECSS-Q-ST-70-02	TML = 0.0005% RML = 0000027% CVCM = 0%
Off-gassing	NHB 8060.1 Test 7 ECSS-Q-ST-70-29	T = 0.00024 for 65 m ³ volume per coupler* MLW (#) = 2112 for 65 m ³ volume*
MTBF according to MIL HDBK-217	-	5.11 x 10 ⁷ hrs at 25°C and Space Flight environment

Out and Off-gassing results, flammability available for all materials used.

* Typical values obtained by AMB/S-C1 coupler during qualification phase.

Mechanical characteristics

PARAMETERS	REQUIRED	ACTUAL
Weight	-	\leq 18 g
Life test	-	1000 hrs at 120°C
Shocks	-	15 g's in all directions
Acceleration	-	20 g's in all directions
Random vibrations	MIL-STD-810, Method 514.5	Functional at 120°C = 16.35 g _{RMS} Endurance at 20°C = 33.23 g _{RMS}

Other mechanical and environmental tests available on request.

Transformer characteristics

PARAMETERS	REQUIRED VALUES (MIL-STD-1553B or SAE AS-4115)	NOMINAL VALUE OR AXON' REQUIRED VALUE	
		NOMINAL VALUE	REQUIRED BY AXON' / QUALITY PLAN
The Curie point	-	-	Over 195°C
Turn ratio	$\sqrt{2} \pm$ 3%	$\sqrt{2} \pm$ 3%	$\sqrt{2} \pm$ 3%
Secondary DC resistance	$R_s < 5 \Omega$	$R_s = 2 \Omega$	$R_s < 2.5 \Omega$
Insulation resistance (winding to winding)	$R_i > 100 M\Omega$	-	$R_i > 1 000 M\Omega$ with a 250 V _{DC} test voltage
Transformer open circuit impedance	$ Z > 3 k\Omega$ on full temperature operating range	$ Z > 10 k\Omega$ at 25°C $ Z > 4.8 k\Omega$ at -65°C	$ Z > 4 k\Omega$ at -85°C $ Z > 9.4 k\Omega$ at 25°C***
Primary parallel inductance	-	22 mH	> 20 mH
Primary parallel capacitance	-	10 pF	< 11.4 pF
Inter-winding capacitance	-	45 pF	-
Primary leakage inductance	-	-	< 6.0 μ H
Droop*	< 20%	4.5%**	< 20%**
Overshoot and ringing*	\pm 1 V	0.30 V**	< \pm 1 V**

* Tested with a 250 kHz square waveform of 27 V_{PP} with 100 ns rise and fall times through a 360 \pm 5% Ω resistor.

** Average values taken during the JN1081N qualification.

*** 9.4 k Ω at 25°C guarantees 3 k Ω from -65°C to +150°C

2 way in-line ESD coupler

SPECIFICATIONS

Microcoupler
MIL-STD-1553B (STANAG 3838)
SSQ 21676 (NASA-BOEING)
PID (CNES), SPE-J-403-A-0070

Testing
AS-SAE-4115

Resistor
MIL-R-39007
MIL-PRF-39017

Solder
ECSS-Q-ST-70-08,
MIL-STD-2000, NHB 5300.4.

Derating
ECSS-Q-ST-30-11

Potting material
ECSS-Q-ST-70-02, ASTM E595,
and ECSS-Q-ST-70-29
or NHB 8060.1.

Connector assemblies
ECSS-Q-ST-70-26
or NHB 5300.4.

Transformer
JN1081 approved
DDP-J-403-A-022
ESA approved
(COF-BCS-PAD01)

All processes, materials
and components are
approved by CNES
(see CNES-PID-02-AXON')
and BOEING/NASA.

ESA: European Space Agency
CNES: French Space Agency
PID: Part Identification Document

AMB / S - C2 - XX - X ESD

Version with bus lines on opposite sides of the coupler.

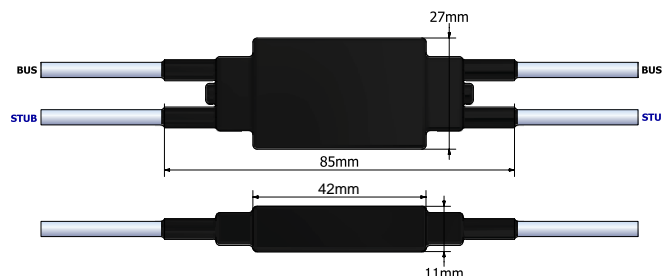

AMB / S - C21 - XX - X ESD

Version with bus lines on same side of the coupler.

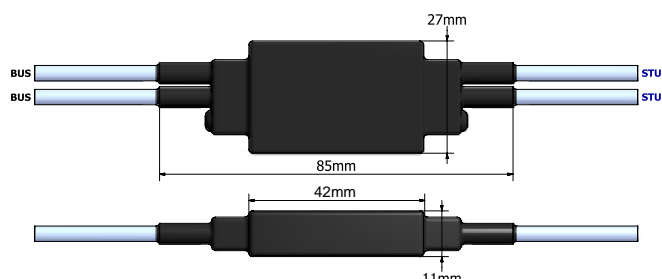

Electrical scheme

$N = 1.41 \pm 3\%$
 $R = \text{fault protection resistance}$
 $R = 0.75 Z_0 = 57.6 \Omega \pm 1\%$
 $R_{ESD} = 2 \text{ M}\Omega$

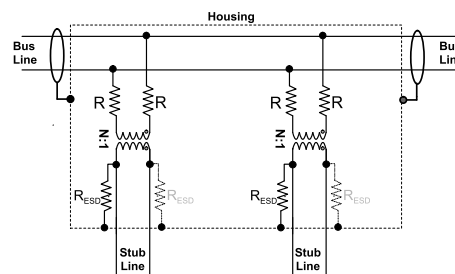

Possibility to have 1 or 2 bleed off resistors of 2 M Ω for each stub line.

Identification code

AMB /

S

CX

XX

X ESD

AXON'
MICROBUS

S: SPACE
VERSION

2: 2 WAY IN-LINE COUPLER
Version with bus lines on
opposite sides of the coupler.

CABLE REFERENCES

- 40: TWINAX BUS AWG 24 SB** (single braid) according to SSQ 21655 (NASA qualified).
41: TWINAX BUS AWG 24 DB (double braid).
43: TWINAX BUS AWG 26 SB (single braid).
44: TWINAX BUS AWG 26 DB (double braid).
45: TWINAX BUS AWG 22 SB (single braid) according to SSQ 21655 (NASA qualified).
80: TWINAX BUS AWG 24 SB (single braid) according to ESCC 3902.002.20.

- 1:** One bleed off resistor for each stub line.
2: Two bleed off resistors for each stub line.

NOTE: CABLE LENGTH AND CABLE COLOUR TO BE DEFINED WHEN ORDERING (possibility to differentiate bus and stub cable with a striped colour tape under the transparent jacket or the extrusion of a colour jacket).

Electrical characteristics

PARAMETERS	REQUIRED	ACTUAL
Nominal line impedance*	70 to 84 Ω	77 Ω
Turn ratio	1.41 ±3%	1.41 ±3%
CMR	< -45 dB at 1 MHz	< -50 dB at 1 MHz
Input impedance	> 1500 Ω in the frequency range (75 kHz to 1 MHz) and in the indicated temp. range (-65°C to 150°C)	> 1500 Ω
Fault protection insulation resistors in series on each bus winding connection	0.75 Z _o ±2%	57.6 Ω ±1%
Stub line bleed off resistor		2 MΩ ±2%
Insulation resistance between:		
- bus / stub	100 MΩ	> 1 000 MΩ at 250 V _{DC}
- bus / shield	100 MΩ	> 1 000 MΩ at 500 V _{DC}
Transfer impedance	-	plot available
Shield continuity	-	10 mΩ maximum
Shield coverage	Cable 90% Connection 75%	Cable 90% minimum Connection 100%
Dielectric withstanding strength:		
- between shield and bus line	500 V _{RMS}	500 V _{RMS}
- between outer insulation and shield	500 V _{RMS}	500 V _{RMS}

* Impedance: seen from the stub when the bus line is loaded with Z_o at both sides of the coupler.

Environmental characteristics

PARAMETERS	REQUIRED	ACTUAL
Operating temperature	-	-65°C to +150°C
Out-gassing	SP-R-0022 - TML < 1% ASTM-E-595 - CVCM < 0.1% ECSS-Q-ST-70-02	TML = 0.0005% RML = 0000027% CVCM = 0%
Off-gassing	NHB 8060.1 Test 7 ECSS-Q-ST-70-29	T = 0.00024 for 65 m ³ volume per coupler* MLW (#) = 2112 for 65 m ³ volume*
MTBF according to MIL HDBK-217	-	2.17 x 10 ⁷ hrs at 25°C and Space Flight environment

Out and Off-gassing results, flammability available for all materials used.

* Typical values obtained by AMB/S-C1 coupler during qualification phase.

Mechanical characteristics

PARAMETERS	REQUIRED	ACTUAL
Weight	-	≤ 27 g
Life test	-	1000 hrs at 120°C
Shocks	-	15 g's in all directions
Acceleration	-	20 g's in all directions
Random vibrations	MIL-STD-810, Method 514.5	Functional at 120°C = 16.35 g _{RMS} Endurance at 20°C = 33.23 g _{RMS}

Other mechanical and environmental tests available on request.

Transformer characteristics

PARAMETERS	REQUIRED VALUES (MIL-STD-1553B or SAE AS-4115)	NOMINAL VALUE OR AXON' REQUIRED VALUE	
		NOMINAL VALUE	REQUIRED BY AXON' / QUALITY PLAN
The Curie point	-	-	Over 195°C
Turn ratio	√2 ±3%	√2 ±3%	√2 ±3%
Secondary DC resistance	R _s < 5 Ω	R _s = 2 Ω	R _s < 2.5 Ω
Insulation resistance (winding to winding)	R _i > 100 MΩ	-	R _i > 1 000 MΩ with a 250 V _{DC} test voltage
Transformer open circuit impedance	Z _I > 3 kΩ on full temperature operating range	Z _I > 10 kΩ at 25°C Z _I > 4.8 kΩ at -65°C	Z _I > 4 kΩ at -85°C Z _I > 9.4 kΩ at 25°C***
Primary parallel inductance	-	22 mH	> 20 mH
Primary parallel capacitance	-	10 pF	< 11.4 pF
Inter-winding capacitance	-	45 pF	-
Primary leakage inductance	-	-	< 6.0 μH
Droop*	< 20%	4.5%**	< 20%**
Overshoot and ringing*	±1 V	0.30 V**	< ±1 V**

* Tested with a 250 kHz square waveform of 27 V_{PP} with 100 ns rise and fall times through a 360 ±5% Ω resistor.

** Average values taken during the JN1081N qualification.

*** 9.4 kΩ at 25°C guarantees 3 kΩ from -65°C to +150°C

3 way in-line ESD coupler

SPECIFICATIONS

Microcoupler
MIL-STD-1553B (STANAG 3838)
SSQ 21676 (NASA-BOEING)
PID (CNES), SPE-J-403-A-0070

Testing
AS-SAE-4115

Resistor
MIL-R-39007
MIL-PRF-39017

Solder
ECSS-Q-ST-70-08,
MIL-STD-2000, NHB 5300.4.

Derating
ECSS-Q-ST-30-11

Potting material
ECSS-Q-ST-70-02, ASTM E595,
and ECSS-Q-ST-70-29
or NHB 8060.1.

Connector assemblies
ECSS-Q-ST-70-26
or NHB 5300.4.

Transformer
JN1081 approved
DDP-J-403-A-022
ESA approved
(COF-BCS-PAD01)

All processes, materials
and components are
approved by CNES
(see CNES-PID-02-AXON')
and BOEING/NASA.

ESA: European Space Agency
CNES: French Space Agency
PID: Part Identification Document

AMB / S - C3 - XX - 1 ESD

Version with bus lines on opposite sides of the coupler.

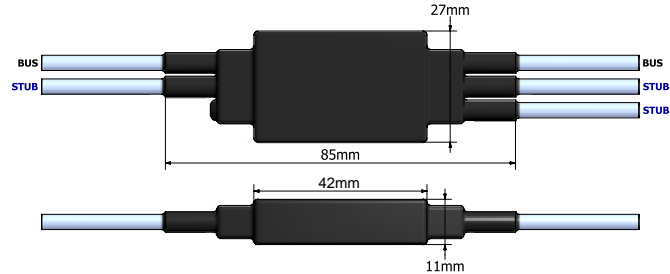

AMB / S - C31 - XX - 1 ESD

Version with bus lines on same side of the coupler.

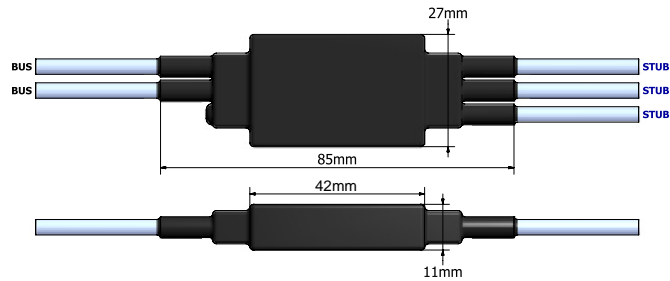

Electrical scheme

$N = 1.41 \pm 3\%$
 $R = \text{fault protection resistance}$
 $R = 0.75 Z_0 = 57.6 \Omega \pm 1\%$
 $R_{ESD} = 2 \text{ M}\Omega$

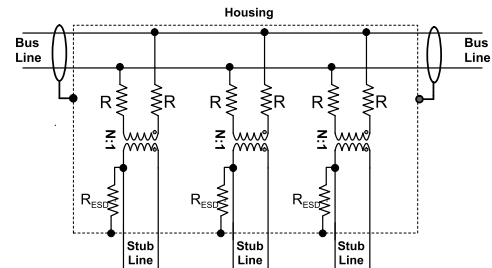

Possibility to have only 1 bleed off resistor of 2 MΩ for each stub line.

Identification code

AMB /

S

CX

XX

1 ESD

AXON'
MICROBUS

S: SPACE
VERSION

3: 3 WAY IN-LINE COUPLER
Version with bus lines on
opposite sides of the coupler.

CABLE REFERENCES

- 40: TWINAX BUS AWG 24 SB** (single braid) according to SSQ 21655 (NASA qualified).
41: TWINAX BUS AWG 24 DB (double braid).
43: TWINAX BUS AWG 26 SB (single braid).
44: TWINAX BUS AWG 26 DB (double braid).
45: TWINAX BUS AWG 22 SB (single braid) according to SSQ 21655 (NASA qualified).
80: TWINAX BUS AWG 24 SB (single braid) according to ESCC 3902.002.20.

1: One bleed off
resistor for each
stub line

NOTE: CABLE LENGTH AND CABLE COLOUR TO BE DEFINED WHEN ORDERING (possibility to differentiate bus and stub cable with a striped colour tape under the transparent jacket or the extrusion of a colour jacket).

Electrical characteristics

PARAMETERS	REQUIRED	ACTUAL
Nominal line impedance*	70 to 84 Ω	77 Ω
Turn ratio	1.41 \pm 3%	1.41 \pm 3%
CMR	< -45 dB at 1 MHz	< -50 dB at 1 MHz
Input impedance	> 1000 Ω in the frequency range (75 kHz to 1 MHz) and in the indicated temp. range (-65°C to 150°C)	> 1000 Ω
Fault protection insulation resistors in series on each bus winding connection	0.75 $Z_0 \pm$ 2%	57.6 $\Omega \pm$ 1%
Stub line bleed off resistor		2 M $\Omega \pm$ 2%
Insulation resistance between:		
- bus / stub	100 M Ω	> 1 000 M Ω at 250 V _{DC}
- bus / shield	100 M Ω	> 1 000 M Ω at 500 V _{DC}
Transfer impedance	-	plot available
Shield continuity	-	10 m Ω maximum
Shield coverage	Cable 90% Connection 75%	Cable 90% minimum Connection 100%
Dielectric withstanding strength:		
- between shield and bus line	500 V _{RMS}	500 V _{RMS}
- between outer insulation and shield	500 V _{RMS}	500 V _{RMS}

* Impedance: seen from the stub when the bus line is loaded with Z_0 at both sides of the coupler.

Environmental characteristics

PARAMETERS	REQUIRED	ACTUAL
Operating temperature	-	-65°C to +150°C
Out-gassing	SP-R-0022 - TML < 1% ASTM-E-595 - CVCM < 0.1% ECSS-Q-ST-70-02	TML = 0.0005% RML = 0000027% CVCM = 0%
Off-gassing	NHB 8060.1 Test 7 ECSS-Q-ST-70-29	T = 0.00024 for 65 m ³ volume per coupler* MLW (#) = 2112 for 65 m ³ volume*
MTBF according to MIL HDBK-217	-	1.87 x 10 ⁷ hrs at 25°C and Space Flight environment

Out and Off-gassing results, flammability available for all materials used.

* Typical values obtained by AMB/S-C1 coupler during qualification phase.

Mechanical characteristics

PARAMETERS	REQUIRED	ACTUAL
Weight	-	\leq 27 g
Life test	-	1000 hrs at 120°C
Shocks	-	15 g's in all directions
Acceleration	-	20 g's in all directions
Random vibrations	MIL-STD-810, Method 514.5	Functional at 120°C = 16.35 g _{RMS} Endurance at 20°C = 33.23 g _{RMS}

Other mechanical and environmental tests available on request.

Transformer characteristics

PARAMETERS	REQUIRED VALUES (MIL-STD-1553B or SAE AS-4115)	NOMINAL VALUE OR AXON' REQUIRED VALUE	
		NOMINAL VALUE	REQUIRED BY AXON' / QUALITY PLAN
The Curie point	-	-	Over 195°C
Turn ratio	$\sqrt{2} \pm$ 3%	$\sqrt{2} \pm$ 3%	$\sqrt{2} \pm$ 3%
Secondary DC resistance	$R_s < 5 \Omega$	$R_s = 2 \Omega$	$R_s < 2.5 \Omega$
Insulation resistance (winding to winding)	$R_i > 100 M\Omega$	-	$R_i > 1 000 M\Omega$ with a 250 V _{DC} test voltage
Transformer open circuit impedance	$ Z > 3 k\Omega$ on full temperature operating range	$ Z > 10 k\Omega$ at 25°C $ Z > 4.8 k\Omega$ at -65°C	$ Z > 4 k\Omega$ at -85°C $ Z > 9.4 k\Omega$ at 25°C***
Primary parallel inductance	-	22 mH	> 20 mH
Primary parallel capacitance	-	10 pF	< 11.4 pF
Inter-winding capacitance	-	45 pF	-
Primary leakage inductance	-	-	< 6.0 μ H
Droop*	< 20%	4.5%**	< 20%**
Overshoot and ringing*	$\pm 1 V$	0.30 V**	< $\pm 1 V$ **

* Tested with a 250 kHz square waveform of 27 V_{PP} with 100 ns rise and fall times through a 360 \pm 5% Ω resistor.

** Average values taken during the JN1081N qualification.

*** 9.4 k Ω at 25°C guarantees 3 k Ω from -65°C to +150°C

Detailed AMB technical informations

Random vibration profile

MIL-STD 810

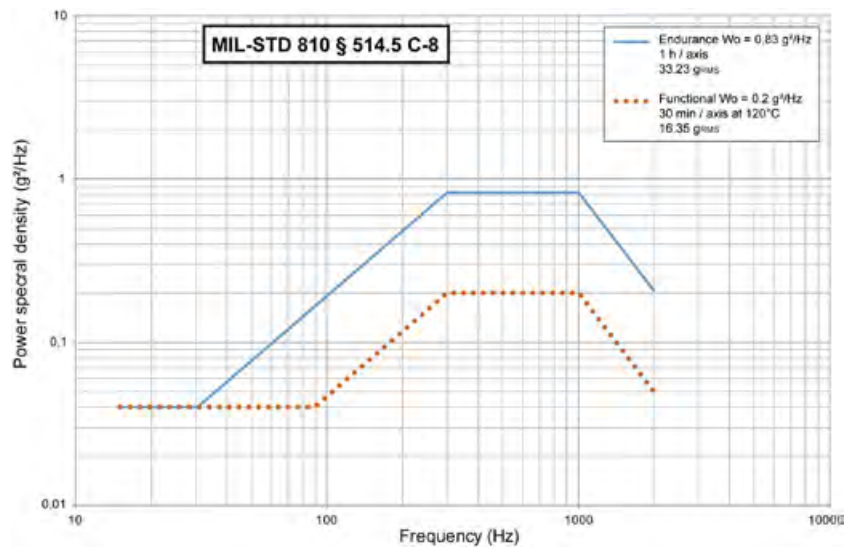

ACB1 databus connectors & contacts

AXON' have developed a triaxial connector called ACB1 (AXON' Connector Bus series 1) suitable for any type of twisted shielded AWG 24 pair cables. The connector is crimped on to cables and assemblies designed and manufactured to MIL-STD-1553.

Advantages

A single crimping tool M22520/5-01 with an AXON' die is required to assemble the connector: no need for two crimp tools, one die and one or two positioning tools like most connectors.

- > ACB1 connectors make assembly easier.
- > ACB1 connectors reduce the time for mounting.
- > No potting is required.
- > ACB1 connectors and mating halves can integrate with either pin or socket contacts: the connector is mounted to your needs.
- > ACB1 connectors have gone through test sequences defined by the EN3716 standard.
- > The only connector approved to ESCC3401/079 by ESA.

Versions

- > 2 types of connectors:
 - bulkhead jack series (BK),
 - Plug series (PG).

Please contact us for ACB1 connectors in space rated version.

- > For each type of connectors, there are 2 versions available:
 - bayonet (4 keyings),
 - threaded.



ACB1 DATABUS CONNECTOR

E-33

axon'
cable & interconnect

© 2004, AXON' CABLE - RELEASED JUNE 2017/E
CABLES & HARNESSSES FOR SPACE APPLICATIONS - www.axon-cable.com

Pin and socket contact for ACB1 connectors

SPECIFICATIONS

MIL-STD-1553B
Digital time division command /
response multiplex databus

MIL-STD-1344
General environmental tests

ASTM-B-196
Material for contact

MIL-G-45204 Class 1
Surface treatment for contact

ACB1 SERIES

Dimensions are in millimetres

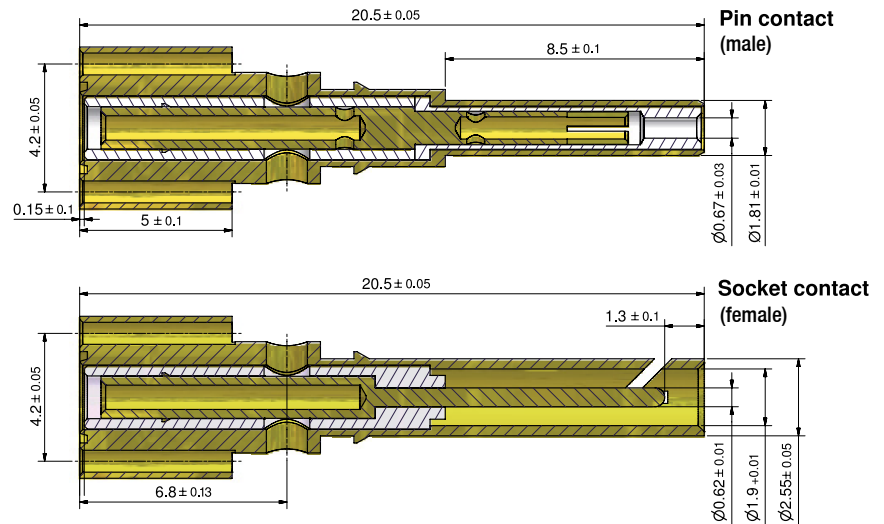

AXON's ACB1 series contact (pin or socket) are designed for databus applications. This contact is to be crimped on AWG24 databus cable and mounted on ACB1 connectors series.

Identification code

ACB1

AXON' CONNECTOR BUS TYPE 1

SR

SR: Space Rated.

X

TYPE OF CONTACT

P: pin contact.
S: socket contact.

Materials and surface treatment

PARAMETERS	ACTUAL
Socket contact	Copper alloy / gold plating in accordance with MIL-G-45204 CLASS 1 (> 1.27 µm)
Pin contact	Copper alloy / gold plating in accordance with MIL-G-45204 CLASS 1 (> 1.27 µm)
Insulator	PTFE

Electrical characteristics

PARAMETERS	ACTUAL
Insulation resistance between inner and outer contacts (sea level)	5 000 MΩ minimum at 500 Vdc
Dielectric withstanding voltage between inner and outer contacts (sea level)	900 V _{RMS} maximum
Contact resistance	8 mΩ maximum

Mechanical and environmental characteristics

PARAMETERS	ACTUAL
Operating temperature	-65°C + 150°C
Socket contact weight	1.5 g maximum
Pin contact weight	1.5 g maximum
Durability (mounting / dismounting)	500 cycles
Sinusoidal vibration	IEC N° 512-4, test 6d, 10-2000 Hz, 20 g
Random vibration	IEC N° 68-2-35, test Fda, 20-2000 Hz, 20 g _{RMS}
Shock	IEC N° 512-4, test 6c, half sine pulse, 11 ms, 50 g

Type of cables

PARAMETERS	ACTUAL
Type of cables	All types of AWG 24 twisted shielded pairs with an outer diameter ≤ 3.8 mm

Tooling used for crimping the contact on the cable

TYPE OF CRIMPING	CRIMPING TOOL	DIE
Contact	M 22520/5-01	AX-CD-02 or AX-CD-03 (*)

(*) Depends on the connector version (refers to technical data sheet)
Crimping according to assembly instructions «CON-1553-GF-27»

ACB1 databus connector

STRAIGHT
& BAYONET
VERSION

SPECIFICATIONS

ESCC 3401
Connectors, electrical, non-filtered
circular and rectangular

ESCC 3401 079
Connectors, electrical, triaxial,
bayonet coupling, MIL-STD-1553B
databus with non-removable crimp
contacts

MIL-STD-1553B
Digital time division command /
response multiplex databus

MIL-STD-1344
General environmental tests

ASTM-B-733
or MIL-C-26074
Surface treatment for
body and ferrule

MIL-G-45204 Class 1
Surface treatment for contact

ESCC 3401 079 variants 09, 10, 13 & 14

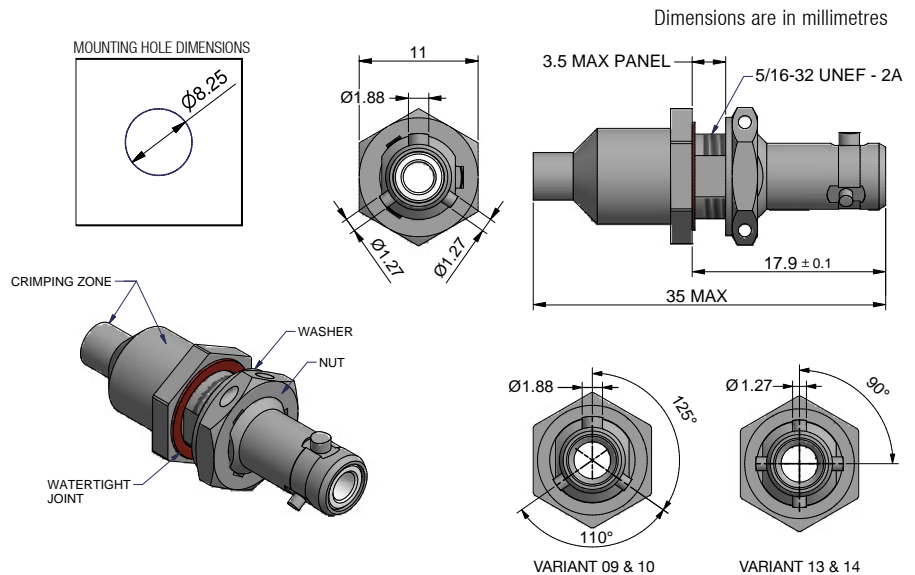

AXON' ACB1 connectors series is specifically designed for MIL-STD-1553 B databus application. Available in bayonet coupling 3A or 4. These connectors are to be crimped on AWG 24 databus cables. The bulkhead jacks are designed to be fixed by using a jam nut and a washer.

CHARACTERISTICS

The connector is composed by 4 main pieces:

- > 1 ferrule,
 - > 1 body,
 - > 1 insulator and
 - > 1 contact (pin or socket),
- and 4 additional pieces:
- > 1 nut,
 - > 1 washer,
 - > 1 watertight joint and
 - > 1 heat shrinkable strain relief.

Variant definition

VARIANT	TYPE	REAR	LOCKING	CONTACT	CABLE
ESCC 3401 079 variant 09	bulkhead jack	straight	3 lug bayonet	socket	cable \leq \varnothing 3.4 mm
ESCC 3401 079 variant 10	bulkhead jack	straight	3 lug bayonet	socket	\varnothing 3.4 mm < cable \leq \varnothing 3.8 mm
ESCC 3401 079 variant 13	bulkhead jack	straight	4 lug bayonet	socket	cable \leq \varnothing 3.4 mm
ESCC 3401 079 variant 14	bulkhead jack	straight	4 lug bayonet	socket	\varnothing 3.4 mm < cable \leq \varnothing 3.8 mm

Materials and surface treatment

PARTS	ACTUAL
Body	Brass / Electroless nickel plating according to ASTM-B-733 (5 ±1 µm)
Socket contact	Copper alloy / gold plating in accordance with MIL-G-45204 CLASS 1 (> 1.27 µm)
Pin contact	Copper alloy / gold plating in accordance with MIL-G-45204 CLASS 1 (> 1.27 µm)
Ferrule	Copper alloy / Electroless nickel plating according to ASTM-B-733 (5 ±1 µm)
Insulator	PTFE
Shrinkable strain relief	VITON®
Watertight joint	Silicon

Electrical characteristics

PARAMETERS	ACTUAL
Contact resistance	8 mΩ maximum
Insulation resistance (sea level)	5 000 MΩ minimum at 500 Vdc
Voltage strength (sea level)	900 V _{RMS} maximum
Operating voltage	200 V _{RMS} maximum

Mechanical and environmental characteristics

PARAMETERS	ACTUAL
Operating temperature	-55°C +150°C
Bulkhead jack with ferrule and contact weight	9 g maximum
Thickness panel	3.5 mm maximum
Torque of fixing nut	2.0 ±0.1 N.m
Salt spray	500 hours
Durability (mounting / dismounting)	500 cycles
Sinusoidal vibration	IEC N° 512-4, test 6d, 10-2000 Hz, 20 g
Random vibration	IEC N° 68-2-35, test Fda, 20-2000 Hz, 20 g _{RMS}
Shock	IEC N° 512-4, test 6c, half sine pulse, 11 ms, 50 g

Type of cables

PARAMETERS	ACTUAL
Type of cables	All types of AWG 24 twisted shield pair with an outer diameter ≤ 3.8 mm

Tooling used for crimping the connector on the cable

TYPE OF CONNECTOR	TYPE OF CRIMPING	CRIMPING TOOL	DIE
Straight versions	Contact	M 22520/5-01	AX-CD-02
	Straight ferrule	M 22520/5-01	AX-CD-02

Crimping according to assembly instructions «CON-1553-GF-27»

ACB1 databus connector

ELBOW &
BAYONET
VERSION

SPECIFICATIONS

ESCC 3401
Connectors, electrical, non-filtered
circular and rectangular

ESCC 3401 079
Connectors, electrical, triaxial,
bayonet coupling, MIL-STD-1553B
databus with non-removable crimp
contacts

MIL-STD-1553B
Digital time division command /
response multiplex databus

MIL-STD-1344
General environmental tests

ASTM-B-733
or MIL-C-26074
Surface treatment for
body and ferrule

MIL-G-45204 Class 1
Surface treatment for contact

MOUNTING HOLE DIMENSIONS

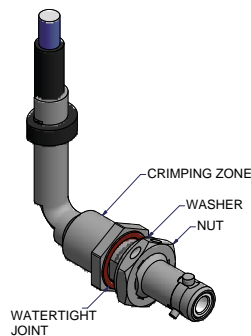
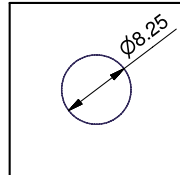

Dimensions are in millimetres

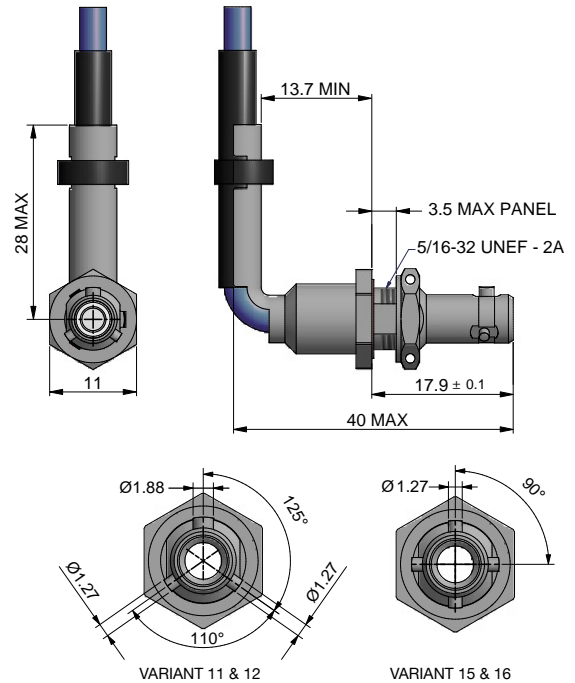

AXON' ACB1 connectors series is specifically designed for MIL-STD-1553 B databus application. Available in bayonet coupling 3A or 4. These connectors are to be crimped on AWG 24 databus cables. The bulkhead jacks are designed to be fixed by using a jam nut and a washer.

CHARACTERISTICS

The connector is composed by 4 main pieces:

- > 1 ferrule,
 - > 1 body,
 - > 1 insulator and
 - > 1 contact (pin or socket),
- and 4 additional pieces:
- > 1 nut,
 - > 1 washer,
 - > 1 watertight joint and
 - > 1 heat shrinkable strain relief.

Variant definition

VARIANT	TYPE	REAR	LOCKING	CONTACT	CABLE
ESCC 3401 079 variant 11	bulkhead jack	right angle	3 lug bayonet	socket	cable \leq \varnothing 3.4 mm
ESCC 3401 079 variant 12	bulkhead jack	right angle	3 lug bayonet	socket	\varnothing 3.4 mm < cable \leq \varnothing 3.8 mm
ESCC 3401 079 variant 15	bulkhead jack	right angle	4 lug bayonet	socket	cable \leq \varnothing 3.4 mm
ESCC 3401 079 variant 16	bulkhead jack	right angle	4 lug bayonet	socket	\varnothing 3.4 mm < cable \leq \varnothing 3.8 mm

Materials and surface treatment

PARTS	ACTUAL
Body	Brass / Electroless nickel plating according to ASTM-B-733 (5 ±1 µm)
Socket contact	Copper alloy / gold plating in accordance with MIL-G-45204 CLASS 1 (> 1.27 µm)
Pin contact	Copper alloy / gold plating in accordance with MIL-G-45204 CLASS 1 (> 1.27 µm)
Ferrule	Copper alloy / Electroless nickel plating according to ASTM-B-733 (5 ±1 µm)
Insulator	PTFE
Shrinkable strain relief	VITON®
Watertight joint	Silicon

Electrical characteristics

PARAMETERS	ACTUAL
Contact resistance	8 mΩ maximum
Insulation resistance (sea level)	5 000 MΩ minimum at 500 V _{dc}
Voltage strength (sea level)	900 V _{RMS} maximum
Operating voltage	200 V _{RMS} maximum

Mechanical and environmental characteristics

PARAMETERS	ACTUAL
Operating temperature	-55°C +150°C
Bulkhead jack with ferrule and contact weight	11.5 g maximum
Thickness panel	3.5 mm maximum
Torque of fixing nut	2.0 ±0.1 N.m
Salt spray	500 hours
Durability (mounting / dismounting)	500 cycles
Sinusoidal vibration	IEC N° 512-4, test 6d, 10-2000 Hz, 20 g
Random vibration	IEC N° 68-2-35, test Fda, 20-2000 Hz, 20 g _{RMS}
Shock	IEC N° 512-4, test 6c, half sine pulse, 11 ms, 50 g

Type of cables

PARAMETERS	ACTUAL
Type of cables	All types of AWG 24 twisted shield pair with an outer diameter ≤ 3.8 mm

Tooling used for crimping the connector on the cable

TYPE OF CONNECTOR	TYPE OF CRIMPING	CRIMPING TOOL	DIE
Swept elbow connectors	Contact	M 22520/5-01	AX-CD-03
	Swept elbow ferrule	M 22520/5-01	AX-CD-03

Crimping according to assembly instructions «CON-1553-GF-27»

A tie-wrap or a lacing lane can be used to maintain the cable onto the ferrule. These items can be provided upon request

ACB1 databus connector

STRAIGHT
& BAYONET
VERSION

SPECIFICATIONS

ESCC 3401
Connectors, electrical, non-filtered
circular and rectangular

ESCC 3401 079
Connectors, electrical, triaxial,
bayonet coupling, MIL-STD-1553B
databus with non-removable crimp
contacts

MIL-STD-1553B
Digital time division command /
response multiplex databus

MIL-STD-1344
General environmental tests

ASTM-B-733
or MIL-C-26074
Surface treatment for
body and ferrule

MIL-G-45204 Class 1
Surface treatment for contact

ESCC 3401 079 variants 01, 02, 05 & 06

Dimensions are in millimetres

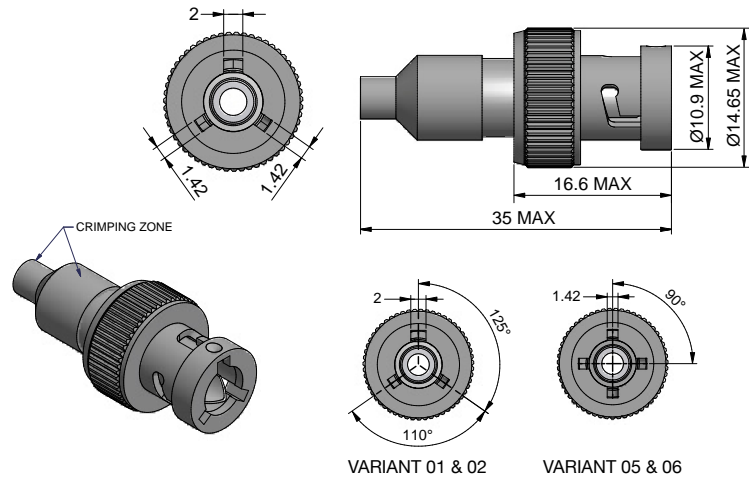

AXON' ACB1 connectors series is specifically designed for MIL-STD-1553 B databus application. Available in bayonet coupling 3A or 4. These connectors are to be crimped on AWG 24 databus cables.

CHARACTERISTICS

The connector is composed by 4 main pieces:

- > 1 ferrule,
 - > 1 body,
 - > 1 insulator and
 - > 1 contact (pin or socket),
- and 1 additional piece:
- > 1 heat shrinkable strain relief.

Variant definition

VARIANT	TYPE	REAR	LOCKING	CONTACT	CABLE
ESCC 3401 079 variant 01	plug	straight	3 lug bayonet	pin	cable \leq \varnothing 3.4 mm
ESCC 3401 079 variant 02	plug	straight	3 lug bayonet	pin	\varnothing 3.4 mm < cable \leq \varnothing 3.8 mm
ESCC 3401 079 variant 05	plug	straight	4 lug bayonet	pin	cable \leq \varnothing 3.4 mm
ESCC 3401 079 variant 06	plug	straight	4 lug bayonet	pin	\varnothing 3.4 mm < cable \leq \varnothing 3.8 mm

Materials and surface treatment

PARTS	ACTUAL
Body	Brass / Electroless nickel plating according to ASTM-B-733 (5 ±1 µm)
Socket contact	Copper alloy / gold plating in accordance with MIL-G-45204 CLASS 1 (> 1.27 µm)
Pin contact	Copper alloy / gold plating in accordance with MIL-G-45204 CLASS 1 (> 1.27 µm)
Ferrule	Copper alloy / Electroless nickel plating according to ASTM-B-733 (5 ±1 µm)
Insulator	PTFE
Shrinkable strain relief	VITON®

Electrical characteristics

PARAMETERS	ACTUAL
Contact resistance	8 mΩ maximum
Insulation resistance (sea level)	5 000 MΩ minimum at 500 V _{DC}
Voltage strength (sea level)	900 V _{RMS} maximum
Operating voltage	200 V _{RMS} maximum

Mechanical and environmental characteristics

PARAMETERS	ACTUAL
Operating temperature	-55°C +150°C
Plug with ferrule and contact weight	14 g maximum
Salt spray	500 hours
Durability (mounting / dismantling)	500 cycles
Sinusoidal vibration	IEC N° 512-4, test 6d, 10-2000 Hz, 20 g
Random vibration	IEC N° 68-2-35, test Fda, 20-2000 Hz, 20 g _{RMS}
Shock	IEC N° 512-4, test 6c, half sine pulse, 11 ms, 50 g

Type of cables

PARAMETERS	ACTUAL
Type of cables	All types of AWG 24 twisted shield pair with an outer diameter ≤ 3.8 mm

Tooling used for crimping the connector on the cable

TYPE OF CONNECTOR	TYPE OF CRIMPING	CRIMPING TOOL	DIE
Straight versions	Contact	M 22520/5-01	AX-CD-02
	Straight ferrule	M 22520/5-01	AX-CD-02

Crimping according to assembly instructions «CON-1553-GF-27»

ACB1 databus connector

ELBOW &
BAYONET
VERSION

SPECIFICATIONS

ESCC 3401
Connectors, electrical, non-filtered
circular and rectangular

ESCC 3401 079
Connectors, electrical, triaxial,
bayonet coupling, MIL-STD-1553B
databus with non-removable crimp
contacts

MIL-STD-1553B
Digital time division command /
response multiplex databus

MIL-STD-1344
General environmental tests

ASTM-B-733
or MIL-C-26074
Surface treatment for
body and ferrule

MIL-G-45204 Class 1
Surface treatment for contact

ESCC 3401 079 variants 03, 04, 07 & 08

Dimensions are in millimetres

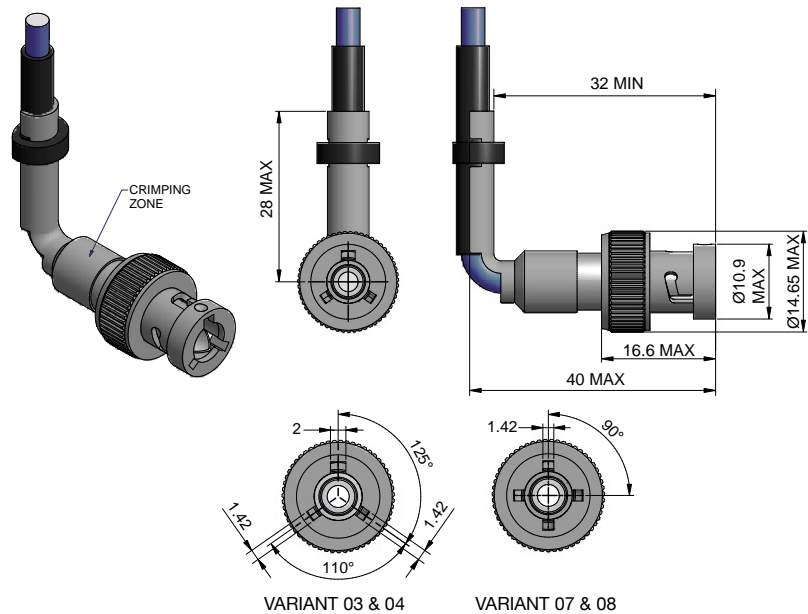

AXON' ACB1 connectors series is specifically designed for MIL-STD-1553 B databus application. Available in bayonet coupling 3A or 4. These connectors are to be crimped on AWG 24 databus cables.

CHARACTERISTICS

The connector is composed by 4 main pieces:

- > 1 ferrule,
 - > 1 body,
 - > 1 insulator and
 - > 1 contact (pin or socket),
- and 1 additional piece:
- > 1 heat shrinkable strain relief.

Variant definition

VARIANT	TYPE	REAR	LOCKING	CONTACT	CABLE
ESCC 3401 079 variant 03	plug	right angle	3 lug bayonet	pin	cable \leq \varnothing 3.4 mm
ESCC 3401 079 variant 04	plug	right angle	3 lug bayonet	pin	\varnothing 3.4 mm < cable \leq \varnothing 3.8 mm
ESCC 3401 079 variant 07	plug	right angle	4 lug bayonet	pin	cable \leq \varnothing 3.4 mm
ESCC 3401 079 variant 08	plug	right angle	4 lug bayonet	pin	\varnothing 3.4 mm < cable \leq \varnothing 3.8 mm

Materials and surface treatment

PARTS	ACTUAL
Body	Brass / electroless nickel plating according to ASTM-B-733 (5 ±1 µm)
Socket contact	Copper alloy / gold plating in accordance with MIL-G-45204 CLASS 1 (> 1.27 µm)
Pin contact	Copper alloy / gold plating in accordance with MIL-G-45204 CLASS 1 (> 1.27 µm)
Ferrule	Copper alloy / electroless nickel plating according to ASTM-B-733 (5 ±1 µm)
Insulator	PTFE
Shrinkable strain relief	VITON®

Electrical characteristics

PARAMETERS	ACTUAL
Contact resistance	8 mΩ maximum
Insulation resistance (sea level)	5 000 MΩ minimum at 500 Vdc
Voltage strength (sea level)	900 VRMS maximum
Operating voltage	200 VRMS maximum

Mechanical and environmental characteristics

PARAMETERS	ACTUAL
Operating temperature	-55°C to +150°C
Plug with ferrule and contact weight	16.5 g maximum
Salt spray	500 hours
Durability (mounting / dismounting)	500 cycles
Sinusoidal vibration	IEC N° 512-4, test 6d, 10-2000 Hz, 20 g
Random vibration	IEC N° 68-2-35, test Fda, 20-2000 Hz, 20 g RMS
Shock	IEC N° 512-4, test 6c, half sine pulse, 11 ms, 50 g

Type of cables

PARAMETERS	ACTUAL
Type of cables	All types of AWG 24 twisted shield pair with an outer diameter ≤ 3.8 mm

Tooling used for crimping the connector on the cable

TYPE OF CONNECTOR	TYPE OF CRIMPING	CRIMPING TOOL	DIE
Swept elbow connectors	Contact	M 22520/5-01	AX-CD-03
	Swept elbow ferrule	M 22520/5-01	AX-CD-03

Crimping according to assembly instructions «CON-1553-GF-27»

ACB1 databus connector

PIGTAIL &
BAYONET
VERSION

SPECIFICATIONS

ESCC 3401

Connectors, electrical, non-filtered
circular and rectangular

ESCC 3401 079

Connectors, electrical, triaxial, bayonet
coupling, MIL-STD-1553B databus
with non-removable crimp contacts

MIL-STD-1553B

Digital time division command /
response multiplex databus

MIL-STD-1344

General environmental tests

ASTM-B-733

or MIL-C-26074

Surface treatment for
body and ferrule

MIL-G-45204 Class 1

Surface treatment for contact

ESCC 3401 079 variants 17 & 18

Dimensions are in millimetres

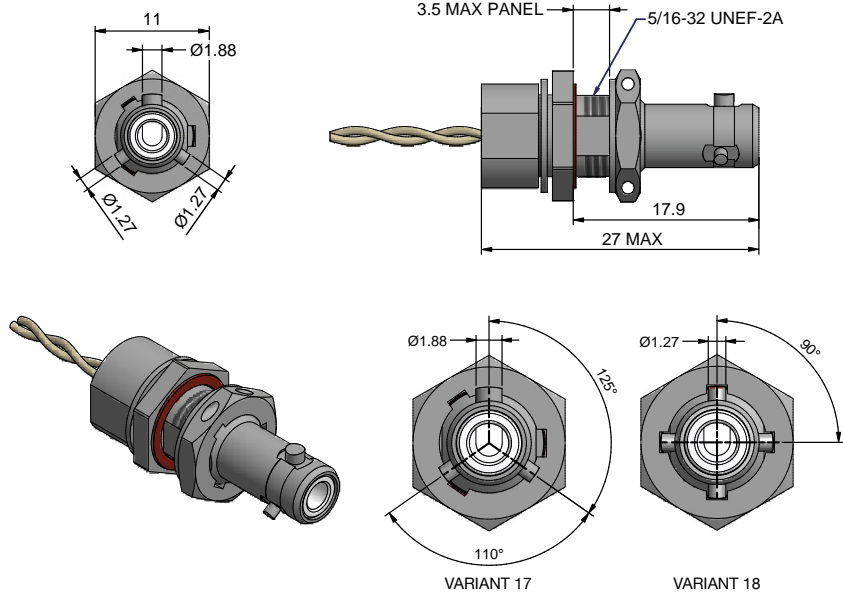

AXON' ACB1 connectors series is specifically designed for MIL-STD-1553 B databus application. Available in bayonet coupling 3A or 4.

CHARACTERISTICS

The connector is supplied assembled with 30 cm of 24AWG twisted pair cable per ESCC 3901.013 variant 08 or equivalent.

Variant definition

VARIANT	TYPE	REAR	LOCKING	CONTACT
ESCC 3401 079 variant 17	bulkhead jack	pigtail	3 lug bayonet	socket
ESCC 3401 079 variant 18	bulkhead jack	pigtail	4 lug bayonet	socket

Materials and surface treatment

PARTS	ACTUAL
Body	Brass / electroless nickel plating according to ASTM-B-733 (5 ±1 µm)
Socket contact	Copper alloy / gold plating in accordance with MIL-G-45204 CLASS 1 (> 1.27 µm)
Pin contact	Copper alloy / gold plating in accordance with MIL-G-45204 CLASS 1 (> 1.27 µm)
Insulator	PTFE
Watertight joint	Silicon

Electrical characteristics

PARAMETERS	ACTUAL
Contact resistance	8 mΩ maximum
Insulation resistance (sea level)	5 000 MΩ minimum at 500 V _{DC}
Voltage strength (sea level)	900 V _{RMS} maximum
Operating voltage	200 V _{RMS} maximum

Mechanical and environmental characteristics

PARAMETERS	ACTUAL
Operating temperature	-55°C to +150°C
Plug with ferrule and contact weight	12 g maximum
Salt spray	500 hours
Durability (mounting / dismantling)	500 cycles
Sinusoidal vibration	IEC N° 512-4, test 6d, 10-2000 Hz, 20 g
Random vibration	IEC N° 68-2-35, test Fda, 20-2000 Hz, 20 g _{RMS}
Shock	IEC N° 512-4, test 6c, half sine pulse, 11 ms, 50 g

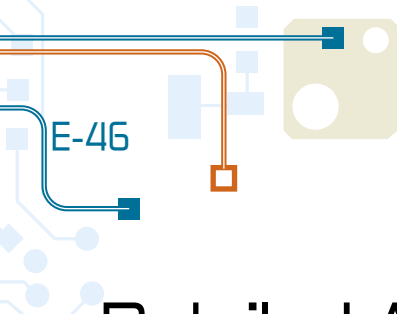

Detailed ACB1 technical informations

Sinusoidal vibration profiles

ESCC 3401

ESCC3401 vibration profile in accordance with IEC standard.

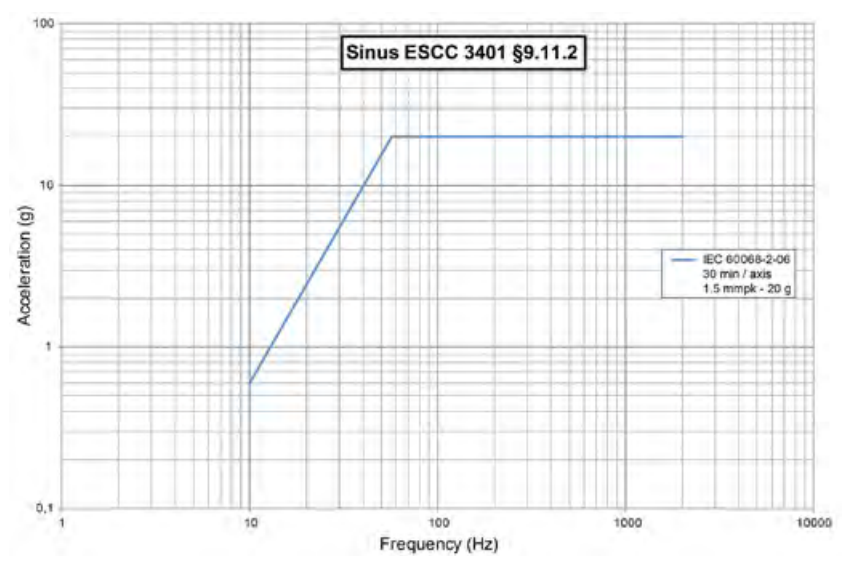

MIL-STD-1344

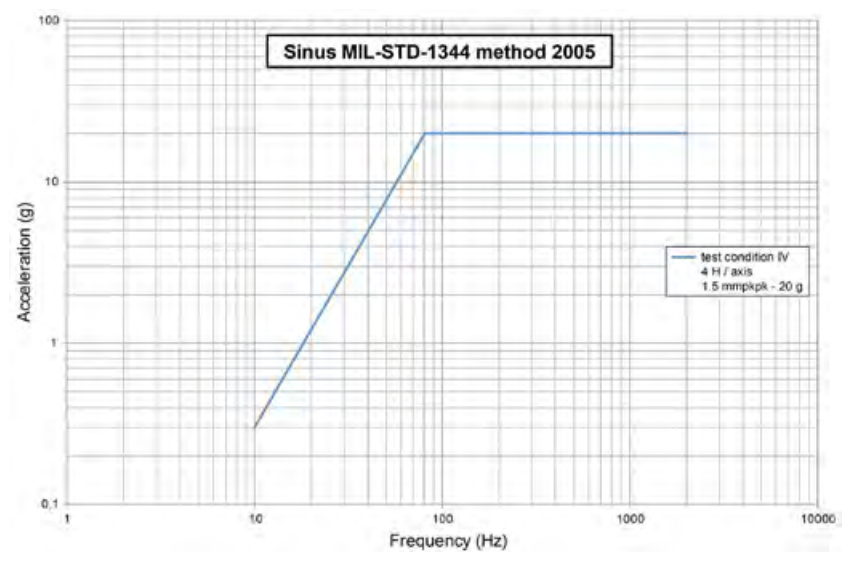

Splices & terminators

Splices

Splices are used to interconnect databus systems without connectors or for repair and maintenance. Their advantages are:

- › Controlled impedance,
- › Good mechanical characteristics,
- › Cost-effective solution,
- › Installed with standard tooling,
- › Lightweight.

Terminators

77 Ω bus terminators used to match the bus line and 3k Ω (or other value on request) terminators used to load a stub line exist in:

- inline version with or without bleed of resistor
- dismountable version on ACB1, D-Sub or other specified connector.



D-SUB DISMOUNTABLE TERMINATOR

E-47

axon' cable & interconnect

© 2004, AXON' CABLE - RELEASED JUNE 2017/E
CABLES & HARNESSES FOR SPACE APPLICATIONS - www.axon-cable.com

In-line databus terminator

SPECIFICATIONS

MIL-STD-1553B (STANAG 3838)

PID (CNES)

Resistor
MIL-R-39007

Solder
ECSS-Q-ST-70-08
MIL-STD-2000, NHB 5300.4

Derating
ECSS-Q-ST-30-11

Potting material
ECSS-Q-ST-70-02, ASTM E595
and ECSS-Q-ST-70-29
or NHB 8060.1.

All processes, materials
and components are
approved by CNES
(see CNES-PID-02AXON').

ESA: European Space Agency
CNES: French Space Agency
PID: Part Identification Document

AMB / S - I - XX

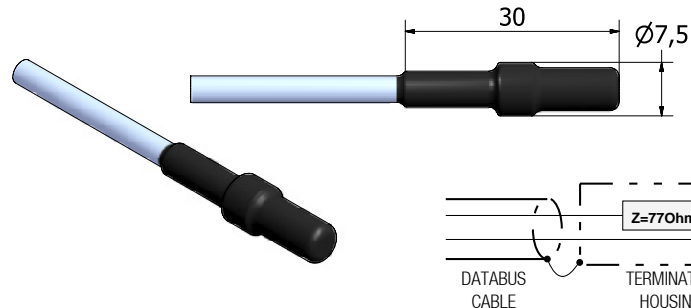

Electrical characteristics

- > Impedance: $Z = 77 \Omega \pm 2\%$
- > Insulation resistance (500 V_{DC}):
 - Outer jacket / conductor: > 1000 M Ω min.
 - Between shield / conductors: > 1000 M Ω min.
- > Dielectric withstanding strength:
 - outer jacket / shield: 500 V_{RMS}
 - Between shield / conductors: 500 V_{RMS}
- > Shield connection resistance: 10 m Ω max.
- > MTBF available following MIL-HDBK 217
(environment and operating temperature to be specified)

Main characteristics

- > Weight: < 3 g (without harnessing accessories)
- > Traction resistance: 100 N
- > Excellent vibration and shock resistance
- > Crush resistance: 500 N

Environmental characteristics

- > Operating temperature: -65°C to +150°C

Identification code

AMB /

S

I

XX

AXON' MICROBUS

(see complete
reference of the
coupler on Bus
Standard sheet,
page 103).

S: SPACE VERSION

IN-LINE BUS TERMINATOR

CABLE REFERENCES

- 40: TWINAX BUS AWG 24 SB (single braid) according to SSQ 21655 (NASA qualified).
- 41: TWINAX BUS AWG 24 DB (double braid).
- 43: TWINAX BUS AWG 26 SB (single braid).
- 44: TWINAX BUS AWG 26 DB (double braid).
- 45: TWINAX BUS AWG 22 SB (single braid) according to SSQ 21655 (NASA qualified).
- 80: TWINAX BUS AWG 24 SB (single braid) according to ESCC 3902.002.20.

NOTE: CABLE LENGTH AND CABLE COLOUR TO BE DEFINED WHEN ORDERING.
These impedances can be integrated in the couplers

In-line ESD databus terminator

SPECIFICATIONS

MIL-STD-1553B (STANAG 3838)

PID (CNES)

Resistor
MIL-R-39007

Solder
ECSS-Q-ST-70-08
MIL-STD-2000, NHB 5300.4

Derating
ECSS-Q-ST-30-11

Potting material
ECSS-Q-ST-70-02, ASTM E595
and ECSS-Q-ST-70-29
or NHB 8060.1.

All processes, materials
and components are
approved by CNES
(see CNES-PID-02AXON').

ESA: European Space Agency
CNES: French Space Agency
PID: Part Identification Document

AMB / S - I - XX - X ESD

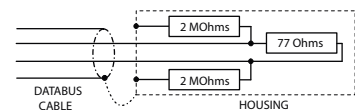
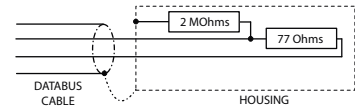
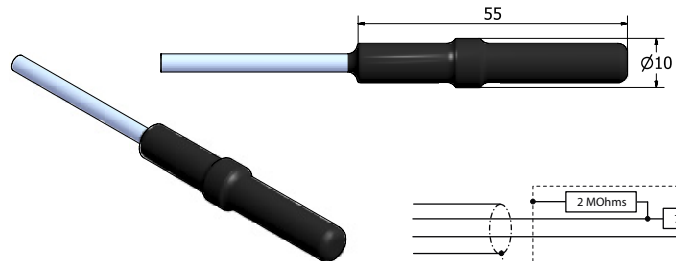

Electrical characteristics

- > Impedance: $Z = 77 \Omega \pm 2\%$
- > Insulation resistance (500 V_{DC}):
 - Outer jacket / conductor: > 1000 M Ω min.
 - Between shield / conductors: > 1000M Ω min.
- > Dielectric withstanding strength:
 - outer jacket / shield: 500 V_{RMS}
 - Between shield / conductors: 500 V_{RMS}
- > Shield connection resistance: 10 m Ω max.
- > MTBF available following MIL-HDBK 217
(environment and operating temperature to be specified).

Main characteristics

- > Weight: < 12 g (without harnessing accessories)
- > Traction resistance: 100 N
- > Excellent vibration and shock resistance
- > Crush resistance: 500 N

Environmental characteristics

- > Operating temperature: -65°C to +150°C

Identification code

AMB /

AXON'
MICROBUS

S

S: SPACE
VERSION

I

IN-LINE BUS TERMINATOR

XX

CABLE REFERENCES

- 40: TWINAX BUS AWG 24 SB** (single braid) according to SSQ 21655 (NASA qualified).
- 41: TWINAX BUS AWG 24 DB** (double braid).
- 43: TWINAX BUS AWG 26 SB** (single braid).
- 44: TWINAX BUS AWG 26 DB** (double braid).
- 45: TWINAX BUS AWG 22 SB** (single braid) according to SSQ 21655 (NASA qualified).
- 80: TWINAX BUS AWG 24 SB** (single braid) according to ESCC 3902.002.20.

X ESD

- 1:** one bleed off resistor.
- 2:** two bleed off resistors.

NOTE: CABLE LENGTH AND CABLE COLOUR TO BE DEFINED WHEN ORDERING.
These impedances can be integrated in the couplers

Dismountable bus terminator or stub impedance

SPECIFICATIONS

MIL-STD-1553B (STANAG 3838)

PID (CNES)

AMB / S - R - or AMB / S - D

CONNECTOR REFERENCE TO BE DEFINED
ACCORDING TO YOUR NEEDS

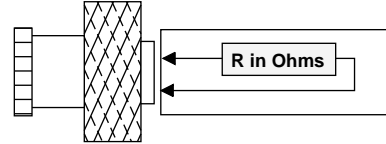

Electrical characteristics

PARAMETERS	ACTUAL
Impedance	
- AMB / S-D = bus terminator	77 Ω
- AMB / S-R = stub impedance	3k Ω or value to be specified
Insulation resistance between shield and conductors	> 1 000 MΩ minimum at 500 Vdc
Dielectric strength between shield and conductors	500 VRMS
Shield connection resistance	Function of connector type

Mechanical and environmental characteristics

PARAMETERS	ACTUAL
Operating temperature	-65°C to +150°C (*)
Weight	according to connector type
Robust, light, compact construction (maximum reduction of space requirement)	
MTBF available following MIL-HDBK 217 (environment and operating temperature to be specified)	

(*) Depends on the connector type.

ESD protection

on request when possible.
A protective passive resistance can be added to evacuate Electrical Static Discharge.

77 Ω TERMINATOR WITH ESD PROTECTION

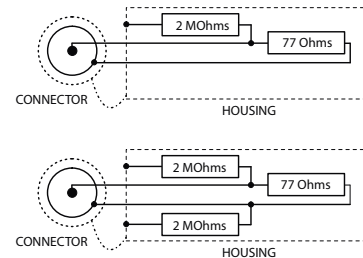

To match the bus line (AMB / S -D) or to load a stub line by high impedance value, the type of connector must be specified)

Identification code

AMB /

S

X

CONNECTOR IDENTIFICATION

AXON' MICROBUS
connector series
to be specified.

S: SPACE VERSION

R: DISMOUNTABLE STUB IMPEDANCE
3 kΩ or value to be specified.

D: DISMOUNTABLE BUS TERMINATOR
77 Ω.

Specified on request.

D-Sub dismountable bus terminator or stub impedance

SPECIFICATIONS

MIL-STD-1553B (STANAG 3838)

PID (CNES)

AMB / S - R
AMB / S - D

D-SUB
SERIES

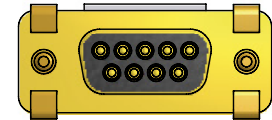

CONNECTOR TO BE DEFINED
ACCORDING TO YOUR NEEDS
(NUMBER OF CONTACTS, DENSITY, SEX)

Use

To match the bus line (AMB / S - D) or to load a stub line by high impedance value, the connector type must be specified.

Electrical characteristics

- > Impedance:
 - AMB / S - D = Bus terminator (77 Ω)
 - AMB / S - R = Stub impedance (3 k Ω or value to be specified)
- > Shield connection resistance: depends on connector type.
- > MTBF available following MIL-HDBK 217 (environment and operating temperature to be specified)

Mechanical characteristics

- > Weight: according to connector type
- > Robust, lightweight, compact construction

Environmental characteristics

- > Operating temperature: -65°C to +150°C

ESD protection

on request when possible.
A protective passive resistance can be added to evacuate Electrical Static Discharge.

Identification code

AMB /

S

X

CONNECTOR IDENTIFICATION

AXON' MICROBUS
Connector series to be specified.

S: SPACE VERSION

R: DISMOUNTABLE STUB IMPEDANCE
3 k Ω or value to be specified.

D: DISMOUNTABLE BUS TERMINATOR
77 Ω .

Specified on request.

ACB1 dismountable databus terminator or stub impedance

SPECIFICATIONS

MIL-STD-1553B
Digital time division
command/ response
multiplex databus

MIL-G-45204 Class 1
Surface treatment
for contact

ASTM-B-733
Surface treatment
for body and ferrule

AMB / SR - R
AMB / SR - D

ACB1
SERIES



BULKHEAD JACK TERMINATOR

SEE THE RELEVANT SPECIFICATION OF THE CONNECTOR

BULKHEAD JACK TERMINATOR

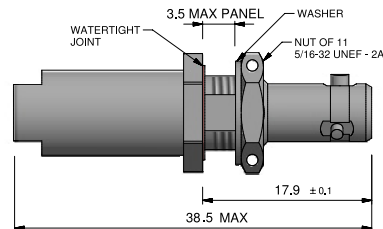

Dimensions are in millimetres

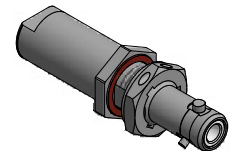

PLUG TERMINATOR

SEE THE RELEVANT SPECIFICATION OF THE CONNECTOR

PLUG TERMINATOR

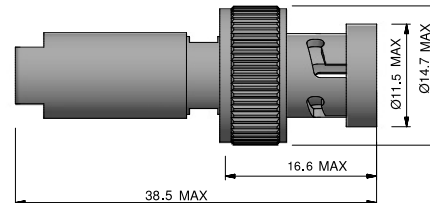

Dimensions are in millimetres

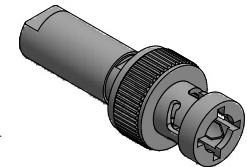

ELECTRICAL SCHEME

AXON's terminators are designed for MIL-STD-1553B databus applications. AXON's terminator is fitted with ACB1 connector.

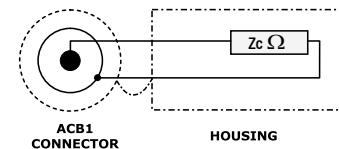

Identification code

AMB	S	X	ACB1	XX	XX	X
AXON' MICROBUS	SR: SPACE RATED VERSION	DISMOUNTABLE TERMINATOR D: 77Ω Impedance. R: 3 kΩ Impedance or value to be specified.	AXON' CONNECTOR BUS TYPE 1	TYPE OF CONNECTOR BK: Bulkhead jack. PG: plug.	TYPE OF CONFIGURATION* 3A: configuration 3A. 04: configuration 04.	TYPE OF CONTACT P: pin contact. S: socket contact.

*= please contact us for
other configurations

Materials and surface treatment

PARTS	ACTUAL
Contact	Copper alloy / golding surface treatment in accordance with MIL-G-45204 CLASS 1 (>1.27 μm)
Body	Brass / electroless nickel plating according to ASTM-B-733 (5 ±1 μm)

Electrical characteristics

PARAMETERS	ACTUAL
Insulation resistance	
Inner contact / Shield (sea level)	1 000 MΩ minimum at 500 Vdc
Shield connection resistance	10 mΩ maximum
Impedance	
Bus terminator	77 Ω nominal
Stub load	3 kΩ nominal or value to be specified

Mechanical and environmental characteristics

PARAMETERS	ACTUAL
Operating temperature	-65°C to +150°C
Bulkhead jack terminator or load	14 g maximum
Plug terminator or load	17 g maximum
Excellent vibration and shock resistance	

Connector configuration

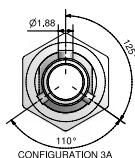
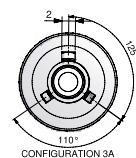
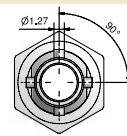
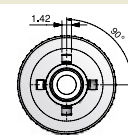
TYPE OF CONFIGURATION	BK CONNECTOR	CORRESPONDING KEYING	PG CONNECTOR	CORRESPONDING KEYING
3A	AMB/SR-X-ACB1-BK 3A	 <p>CONFIGURATION 3A</p>	AMB/SR-X-ACB1-PG 3A	 <p>CONFIGURATION 3A</p>
04	AMB/SR-X-ACB1-BK 04	 <p>CONFIGURATION 4 (-)</p>	AMB/SR-X-ACB1-PG 04	 <p>CONFIGURATION 4 (-)</p>

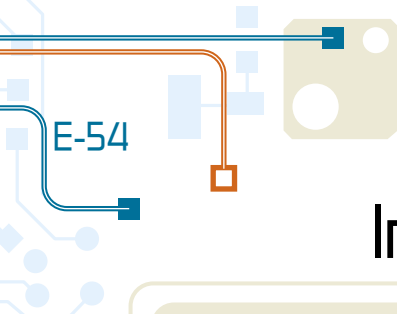

In-line databus splice crimp

SPECIFICATIONS

MIL-STD-1553 B
Digital time division
command / response multiplex
databus

MIL-C-39029
Contacts, electrical
connector, general
specification

AMB / S - S - XX

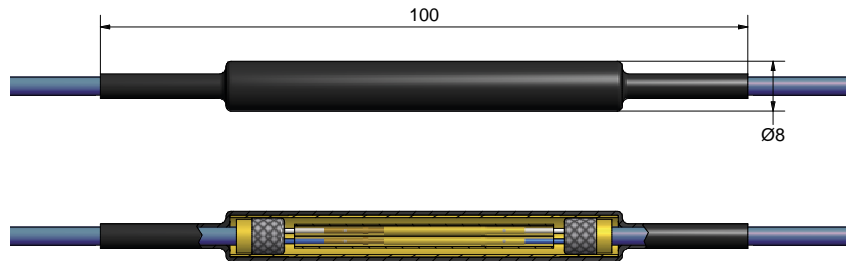

Length end-to-end including heat shrink tube.

DIMENSIONS in mm

AXON's AMB/S-S-xx splices are designed for MIL-STD-1553 B databus applications. These splices are crimp terminated, can be fitted to AWG 24 & 26 databus cables and are designed to comply with MIL-STD-1553B.

Construction

The splice consists of 11 pieces as follows:

- | | | | |
|---|--|---|--|
| 1 | | 1 | CRIMP FERRULES FOR SINGLE OR DOUBLE BRAID CABLE |
| 2 | | 3 | M39029/58-360 PIN CONTACT |
| 4 | | 3 | M39029/56-348 SOCKET CONTACT |
| 5 | | 4 | INNER HEAT-SHRINKABLE TUBING (1/16") (PRIMARY INSULATION) |
| 6 | | 5 | INNER HEAT-SHRINKABLE TUBING (1/8") (SECONDARY INSULATION) |
| 7 | | 6 | HOUSING |
| | | 7 | INSULATION OUTER HEAT-SHRINKABLE PART |

Identification code

AMB /	S	S	XX
AXON' MICROBUS	S: SPACE VERSION	SPLICE	TYPE OF FERRULE SB for single braid cable. DB for double braid cable.

Materials and plating

COMPONENT	MATERIAL / PLATING
Inner contacts	Brass / Gold plated
Housing / ferrule	Brass / Gold plated
Heat shrinkable sleeves	VITON®

Mechanical characteristics

PARAMETERS	
Weight	6 g maximum

Electrical characteristics

PARAMETERS	VALUE	UNITS	MIN / MAX
Insulation resistance (under 500 DC)	1000	M Ω	minimum
Contact resistance	8	m Ω	maximum
Characteristic impedance	77	Ω	nominal

Type of cables

PARAMETER	ACTUAL
Type of cables	All types of AWG 26 to 24 shielded twisted pairs with an outer diameter < 3.8 mm

Tooling used for crimping the AMB/S-S-XX splice

AXON' CABLING INSTRUCTION: 95021-PM_SPLICE-01-A
(respect the crimping rules for MIL-C-39029 contacts or ESA-ECSS-Q-70-26 for space applications)

TYPE OF CRIMPING	CRIMPING TOOL	DIE
PIN CONTACT	M22520/2-01	M22520/2-09 Setting 2 for AWG 26 Setting 4 for AWG 24
SOCKET CONTACT	M22520/2-01	M22520/2-07 Setting 2 for AWG 26 Setting 4 for AWG 24
HOUSING	M22520/10-01	M22520/10-23

VITON® IS A REGISTERED TRADEMARK OF DUPONT